

EX: In the circuit below, use Kirchhoff's voltage and current laws to write equations relating voltages and currents.

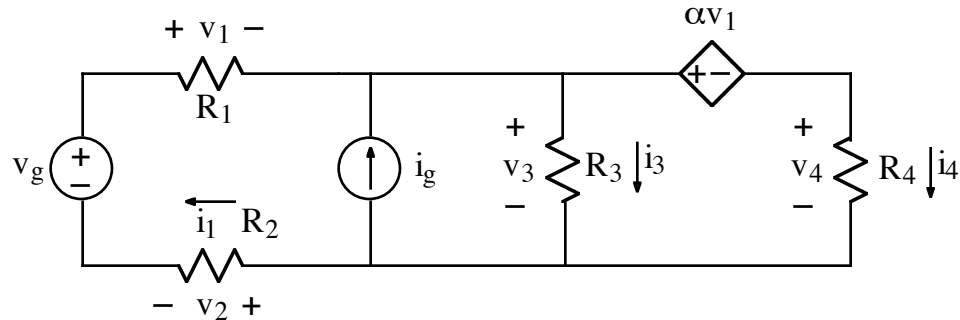

ANSWER:

$$-i_1 - i_g + i_3 + i_4 = 0$$

$$+v_g - v_1 - v_3 - v_2 = 0$$

$$+v_3 - \alpha v_1 - v_4 = 0$$

SOL'N: We avoid labels defining the current for a voltage source or the voltage for a current source. Thus, we look for nodes where every branch has a labeled current, (i.e., contains at least one resistor or current source, as opposed to only v-sources), and v-loops where the loop where every element has a labeled voltage, (i.e., without current sources).

We sum the currents flowing out of the top center node. (Writing an equation for the bottom node would be redundant.) Note that, because a wire connects them, we consider the two top-center nodes as a single node. (We may redraw the circuit with the wire collapsed to a point.) Note also that current i_1 continues around the loop to flow through R_1 from left to right, and current i_4 flows through the dependent source.

Because writing v-loop equations for the left or center inner loops would require defining a voltage for a current source, we write a v-loop equation for the next larger loop that goes around the current source. We also write a v-loop equation for the inner loop on the right.

Our voltage loops start from the lower left and proceed in a clockwise direction. We may start voltage loops wherever we desire, but being consistent tends to improve accuracy.