

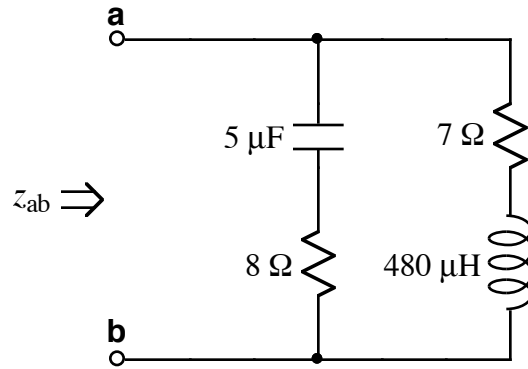

1.



Given  $\omega = 50 \text{ k rad/s}$ , find  $z_{ab}$ .

2.

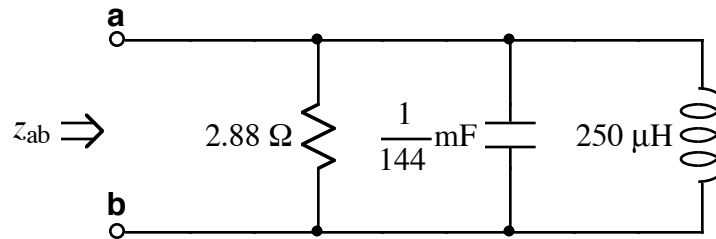

Find a frequency,  $\omega$ , that causes  $z_{ab}$  to have a phase angle of  $-45^\circ$ , (i.e., imaginary part is the negative of the real part). Hint: use admittance, (the reciprocal of impedance).

3.

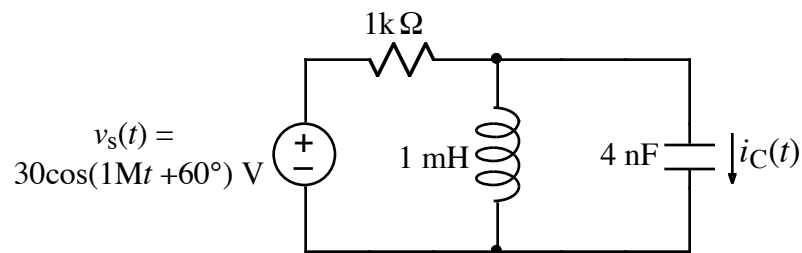

- Find the phasor value for  $v_s(t)$ .
- Draw the frequency-domain circuit diagram, including the phasor value for  $v_s(t)$  and impedance values for components.

4. Find the phasor value for  $i_C(t)$ .

5.

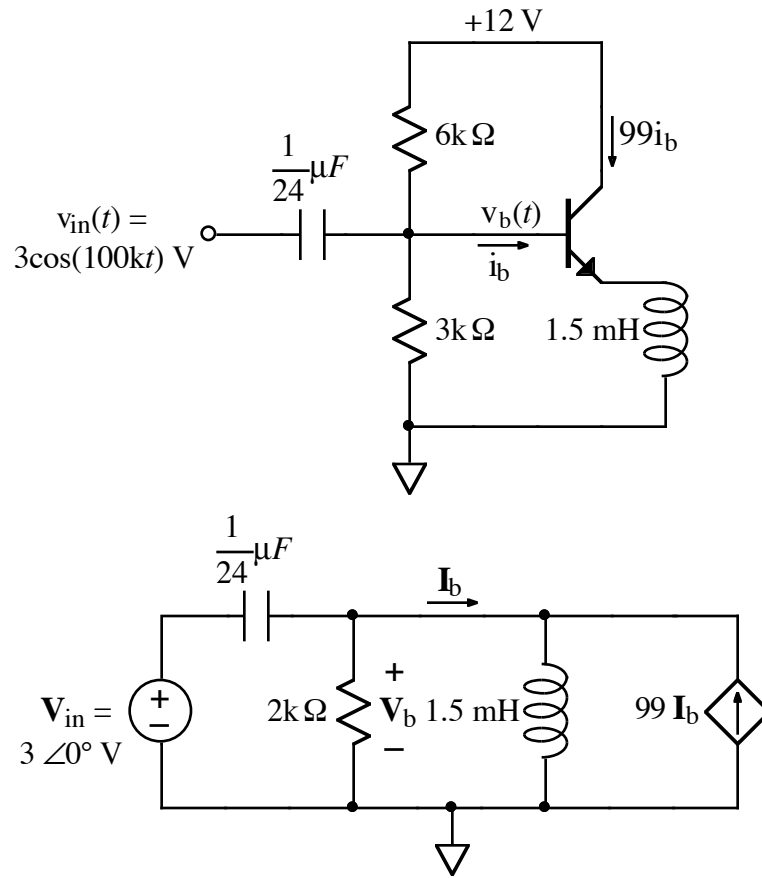

The above circuit diagrams show an emitter-follower amplifier and its high-frequency equivalent circuit. Find  $v_b(t)$ .