

ECE 2210 Lecture 4 notes Superposition

Circuits with more than one Source

A. Stolp
9/3/08,
7/31/09

Recall Statics. To find the reaction at each support, the reactions to each load on a beam (or anything else) can be found separately for each load. Simply add them up to find the total reactions.

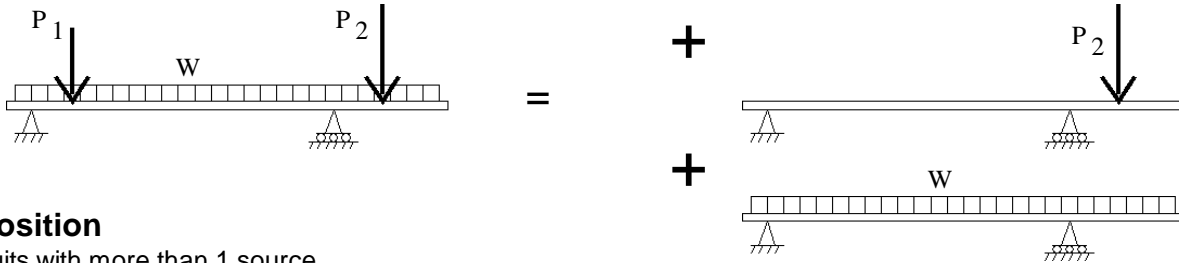

Superposition

For circuits with more than 1 source.

1) Zero all but one source.

(To zero a voltage source, replace it with a short. To zero a current source, replace it with an open.)

2) Compute your wanted voltage or current due to the remaining source. Careful, some may be negative.

3) Repeat the first two steps for all the sources.

4) Sum all the contributions from all the sources to find the actual voltage or current. **Watch your signs!**

Ex1. Use the method of superposition to find the current I_2 (through R_2) and the voltage across R_1 (V_{R1}). Be sure to clearly show and **circle** your intermediate results.

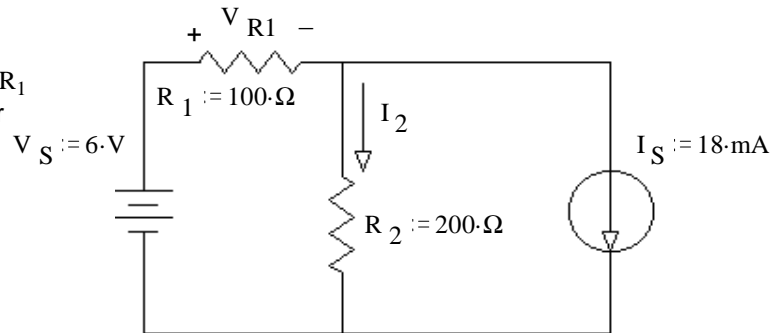

superposition:

Eliminate current source

$$I_{2,V_S} := \frac{V_S}{R_1 + R_2}$$

$$I_{2,V_S} = 20 \cdot \text{mA}$$

$$V_{R1,V_S} := \frac{R_1}{R_1 + R_2} \cdot V_S$$

$$V_{R1,V_S} = 2 \cdot \text{V}$$

$$20 \cdot \text{mA} \cdot 100 \cdot \Omega = 2 \cdot \text{V}$$

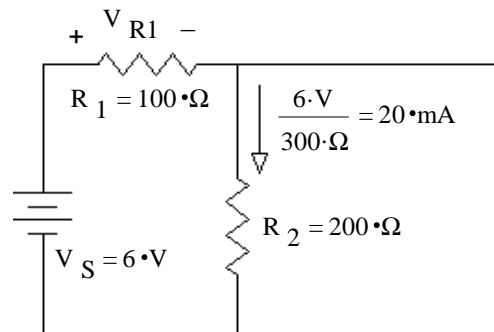

Eliminate voltage source

$$I_{2,I_S} := -\frac{\frac{1}{R_2}}{\frac{1}{R_1} + \frac{1}{R_2}} \cdot I_S$$

$$I_{2,I_S} = -6 \cdot \text{mA}$$

$$V_{R1,I_S} := -I_{2,I_S} \cdot R_2$$

$$V_{R1,I_S} = 1.2 \cdot \text{V}$$

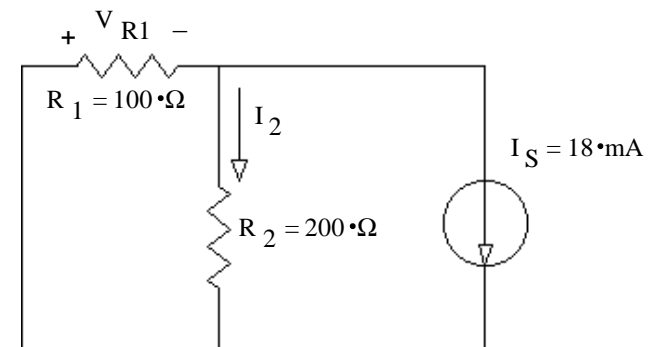

Add results

$$I_2 := I_{2,V_S} + I_{2,I_S}$$

$$I_2 = 14 \cdot \text{mA}$$

$$V_{R1} := V_{R1,V_S} + V_{R1,I_S}$$

$$V_{R1} = 3.2 \cdot \text{V}$$

ECE 2210 Lecture 4 notes p2

Ex2. Use the method of superposition to find the voltage across R_2 and the current through R_3 . Be sure to clearly show and **circle** your intermediate results.

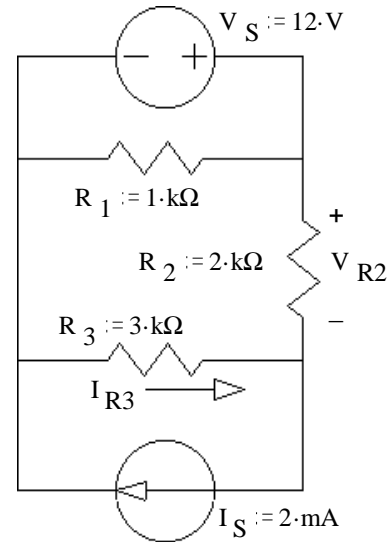

Eliminate current source

R_1 is a separate path and doesn't matter.

$$V_{R2.Vs} := \frac{R_2}{R_2 + R_3} \cdot V_S \quad V_{R2.Vs} = 4.8 \cdot V$$

$$I_{R3.Vs} := -\frac{V_S}{R_2 + R_3} \quad I_{R3.Vs} = -2.4 \cdot mA$$

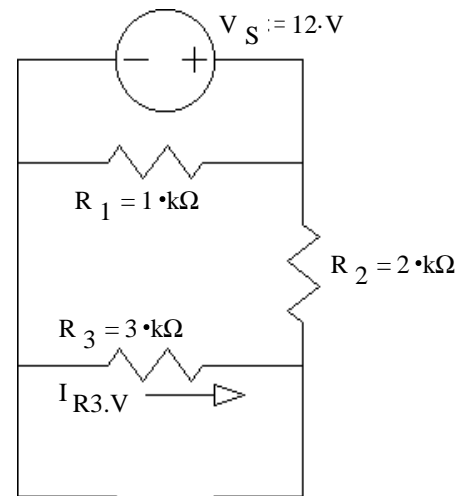

Eliminate voltage source

R_1 is shorted and doesn't matter.

$$V_{R2.Is} := I_S \cdot \frac{1}{\frac{1}{R_2} + \frac{1}{R_3}} \quad V_{R2.Is} = 2.4 \cdot V$$

$$I_{R3.Is} := \frac{\frac{1}{R_3}}{\frac{1}{R_2} + \frac{1}{R_3}} \cdot I_S \quad I_{R3.Is} = 0.8 \cdot mA$$

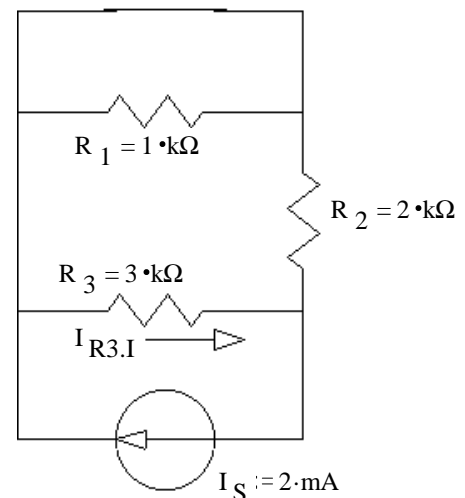

Add results

$$V_{R2} := V_{R2.Vs} + V_{R2.Is} \quad V_{R2} = 7.2 \cdot V$$

$$I_{R3} := I_{R3.Vs} + I_{R3.Is} \quad I_{R3} = -1.6 \cdot mA$$

Answer the following problems on your own paper or tablet.

Since you have the answers, you **must show** the equations and work you used to arrive at the answer to get credit.

Equivalent resistance

1. Find the equivalent resistance of each of these networks, i.e. what would an ohmmeter read if hooked to the terminals. Work out and keep all your intermediate results -- they will help you in the problems to come.

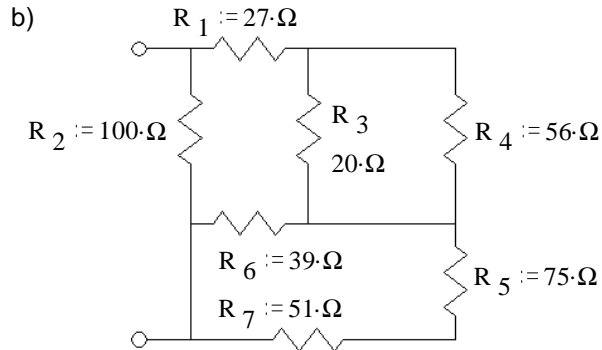
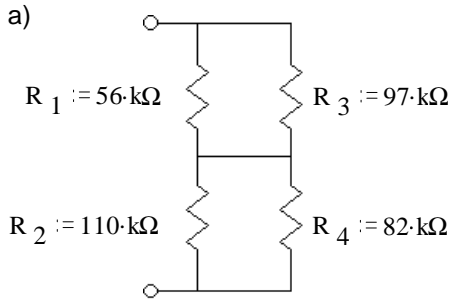

Note: the hard part of these problems is actually seeing which resistors are in parallel and which are in series. You may want to redraw the circuits a few times to help you figure it out.

Voltage dividers

2. a) Use the voltage divider concept to find the voltage across each of the resistors in the circuit at right. $V_{R1} = ?$ $V_{R2} = ?$ $V_{R3} = ?$
 b) Confirm that the three resistor voltages add up to the source voltage, ie, confirm Kirchoff's voltage law.
 c) Without recalculating anything, what would happen to all the resistor voltages if the source voltage were doubled? Tripled?

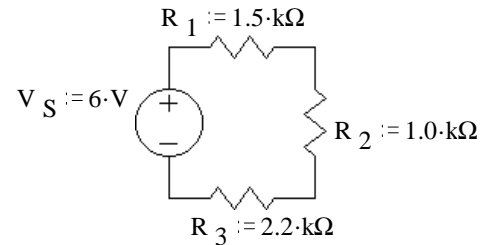

3. The circuit at right is known as a *wheatstone bridge*, or simply a *bridge*. It is a very common measurement circuit, used with strain gauges, thermistors, and other devices whose resistance changes in response to something that you'd like to measure. Let's assume the resistors in this circuit are 100Ω strain gauges. The resistance of these gauges changes slightly when you stretch or compress them. They are glued to a material (often steel) and are used to measure deformations of the material (called strain).

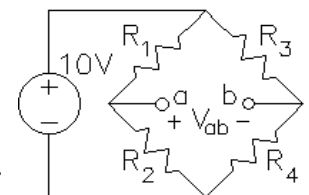

- a) Due to deformation, R_1 and R_4 decrease by 1% and R_2 and R_3 increase by 1%. Find V_{ab} .
 b) Due to a temperature change, the resistances of all the gages increase by 5%. Find the % change in V_{ab} .
 c) Why do you think the bridge circuit is used in this case?
 4. Use voltage divider concepts to find the voltages indicated in the following circuits. You may want to use some of your results from problem 1. You may need to use the voltage divider equation more than once.

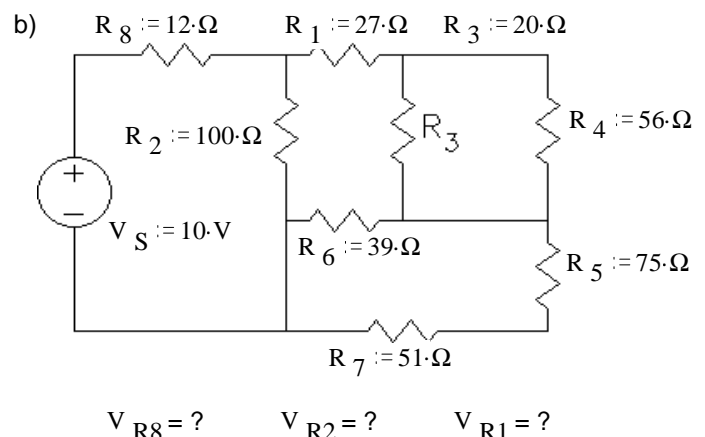
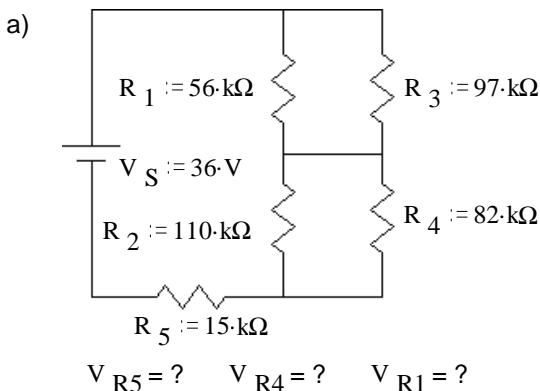

ECE 2210 / 00 homework # 3 p.2

Current Dividers

5. The circuit at right shows a current source hooked to a resistor network. Remember that the grounds are all connected together. You can draw lines between them if it helps you.

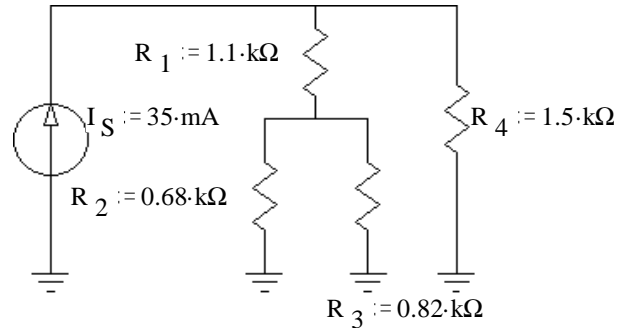

a) Use the current divider concept to find the current through each of the resistors in the circuit at right.

$$I_{R1} = ? \quad I_{R2} = ? \quad I_{R3} = ? \quad I_{R4} = ?$$

b) Confirm that $I_{R2} + I_{R3} = I_{R1}$ and that $I_{R1} + I_{R4} = I_S$, ie, confirm Kirchoff's current law twice.

c) Without recalculating anything, what would happen to all the currents if the source current were doubled? Tripled?

6. Refer back to the circuit of problem 4b.

a) Find the equivalent resistance as seen by the source (R_8 + your answer for problem 1b) and use that to find the source current (I_S or I_{R8}).

b) Find these currents by current divider methods. $I_{R2} = ? \quad I_{R1} = ? \quad I_{R4} = ?$

c) Using Ohm's law and the currents you found in this problem, confirm the voltages found in problem 4b.

Power

7. Refer to the circuit of problem 2.

a) How much power is dissipated by each resistor? $P_{R1} = ? \quad P_{R2} = ? \quad P_{R3} = ?$

b) Independently determine the power that the source is contributing to the circuit. $P_S = V_S \cdot I_S = ?$

c) Show that power is conserved (Σ answers to a = answer to b).

8. Refer to the circuit of problem 5.

a) How much power is dissipated by each resistor? $P_{R1} = ? \quad P_{R2} = ? \quad P_{R3} = ? \quad P_{R4} = ?$

b) Independently determine the power that the source is contributing to the circuit. $P_S = V_S \cdot I_S = ?$

c) Show that power is conserved.

9. The circuit at right has five unknown components labeled A through E.

a) Which of the components are absorbing power from the circuit?

b) Which of the components are contributing power to the circuit?

c) Show that power is conserved.

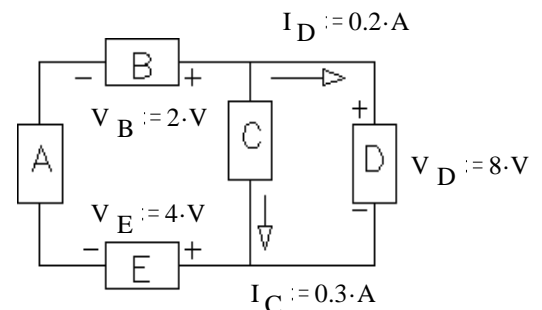

Answers

1. a) $R_{eq} := 82.5 \cdot k\Omega$

b) $R_{eq} := 41.7 \cdot \Omega$

2. a) $1.91 \cdot V, 1.28 \cdot V, 2.81 \cdot V$

b) $1.91 \cdot V + 1.28 \cdot V + 2.81 \cdot V = 6 \cdot V$

c) double, triple

3. a) $100 \cdot mV$ b) 0% change

c) Reading won't be affected by temperature.

4. a) $5.54 \cdot V, 17.35 \cdot V, 13.11 \cdot V$

b) $2.23 \cdot V, 7.77 \cdot V, 2.93 \cdot V$

5. a) $17.67 \cdot mA, 9.66 mA, 8.01 \cdot mA, 17.33 \cdot mA$

b) both check

c) double, triple

6. a) $53.7 \cdot \Omega, 0.186 \cdot A$

b) $77.65 \cdot mA, 108.6 \cdot mA, 28.6 \cdot mA$

c) all agree

7. a) $2.44 \cdot mW, 1.63 \cdot mW, 3.59 \cdot mW$

b) $7.66 \cdot mW$

c) $P_S = P_{R1} + P_{R2} + P_{R3}$

8. a) $0.343 \cdot W, 0.0634 \cdot W, 0.0526 \cdot W, 0.451 \cdot W$

b) $0.910 \cdot W$

c) $P_{R1} + P_{R2} + P_{R3} + P_{R4} = P_S$

9. a) C, D, E

b) A, B

c) $6 \cdot W = 6 \cdot W$

Answer the following problems on your own paper. Show your equations and work to get credit on this and all future homeworks.

Superposition

- Use superposition to find I_3 . Circle your intermediate solutions on your paper. Your intermediate solutions show how much of I_3 is due to V_{S1} , and how much is due to V_{S2} .

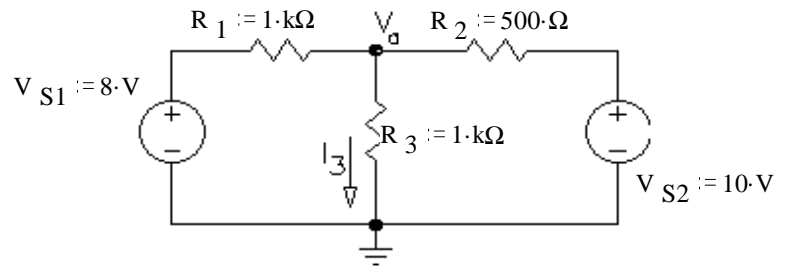

- Use superposition to solve following problems: Each problem asks for both a current and a voltage. Clearly indicate your intermediate answers, the grader will look for those.

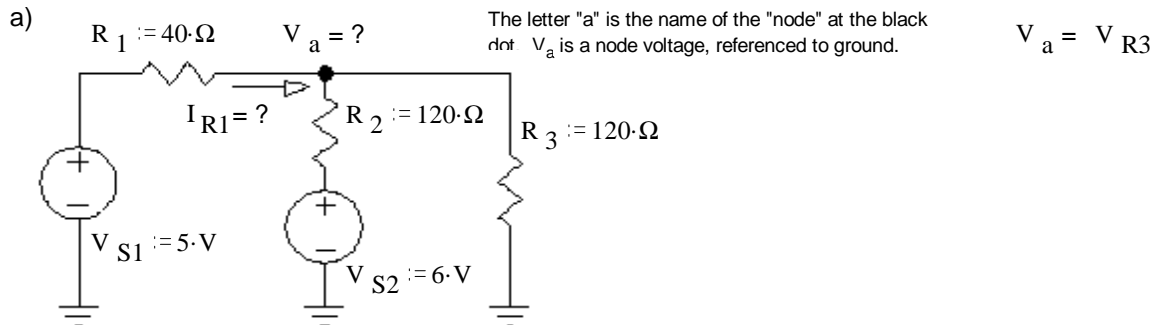

These are ground symbols. They are all connected together, although that connection is not explicitly shown.

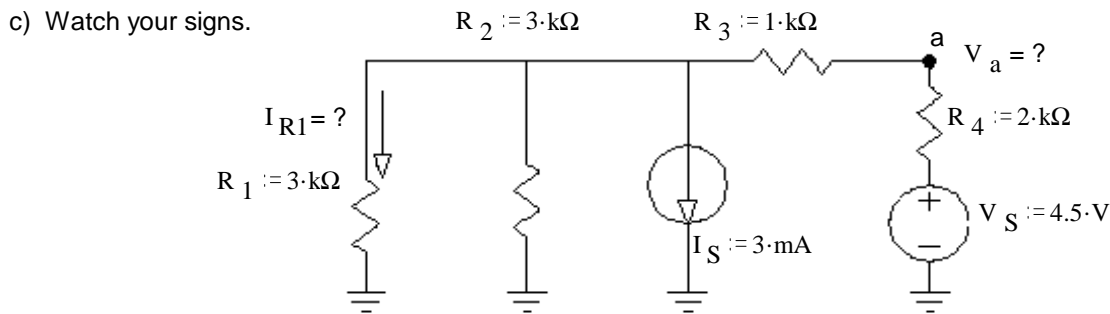
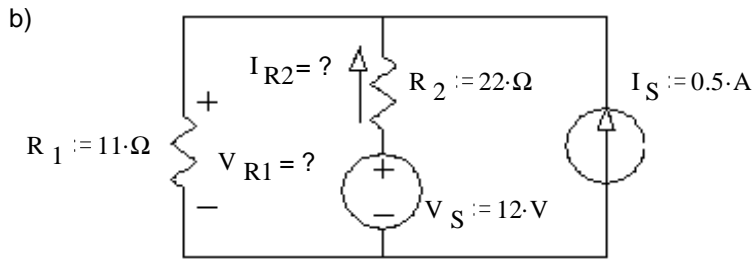

Answers

- $2\text{mA} + 5\text{mA} = 7\text{mA}$
- a) 4.2V , 20mA b) 7.67V , 197mA
- c) 0.5V , -0.5mA