

ECE 2210 Exam 3 given: Fall 18

1. (22 pts) a) Draw the asymptotic Bode plot (the straight-line approximation) of the transfer function shown. Accurately draw it on the graph provided.

$$H(f) := \frac{(3 \cdot \text{kHz} + j \cdot f) \cdot \left(1 \cdot \text{Hz} + \frac{j \cdot f}{20}\right)}{j \cdot f \cdot \left(\frac{j \cdot f}{400} + 100 \cdot \text{Hz}\right)}$$

You must show the steps you use to get the Bode plot. That is, show things like the corner frequency(ies), the approximations of the transfer function in each frequency region, calculations of dB, etc..

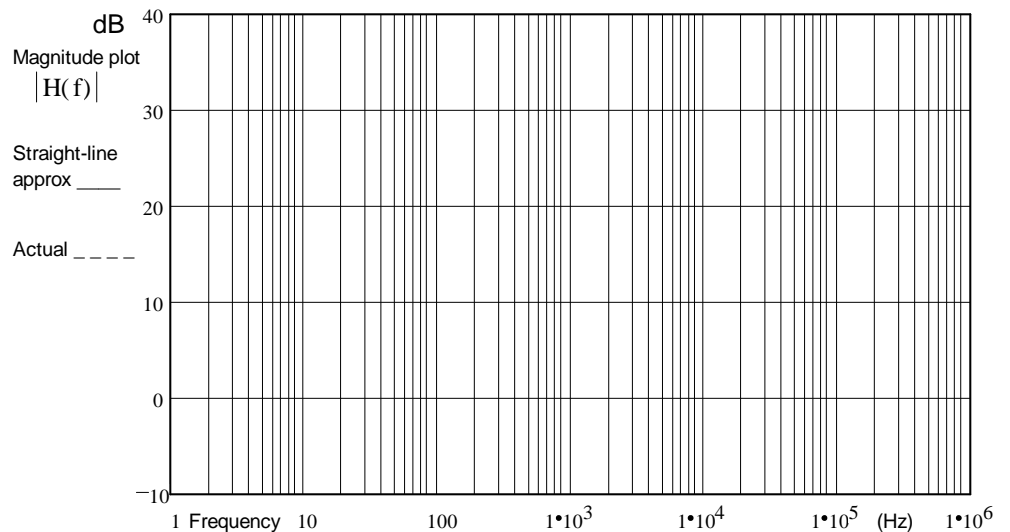

- b) The asymptotic Bode plot is not exact. Using a dotted line, sketch the actual magnitude of the transfer function $|H(f)|$ on the plot above. Indicate the point(s) where the difference between the two lines is the biggest (draw arrow(s)) and write down the actual magnitude(s) at that (those) point(s).

2. (21 pts) a) A feedback system is shown in the figure. What is the transfer function of the whole system, with feedback.

$$\mathbf{H}(s) = \frac{\mathbf{X}_{\text{out}}(s)}{\mathbf{X}_{\text{in}}(s)} = ?$$

Simplify your expression for $\mathbf{H}(s)$ so that the denominator is a simple polynomial in standard form.

Be clear about your signs, so I can tell you know what you're doing & where signs may cancel.

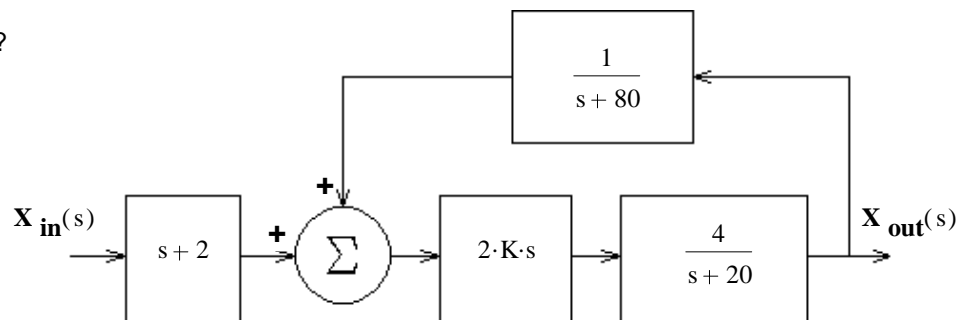

- b) Find the value of K to make the transfer function critically damped.

- c) If K is **less** than this value the system will be: underdamped or overdamped Circle one

- d) Does the transfer function have a zero? Answer "no" or find the s value(s) of the zero(s). **ECE 2210 E 3 Fall 18 p1**

ECE 2210 Exam 3 Fall 18 p2

3. (33 pts) The switch has been open for a long time and is closed (as shown) at time $t = 0$. SHOW YOUR WORK, no credit for guesses!
 a) What are the final conditions of i_L and the v_C ?
 $i_L(\infty) = ? \quad v_C(\infty) = ?$

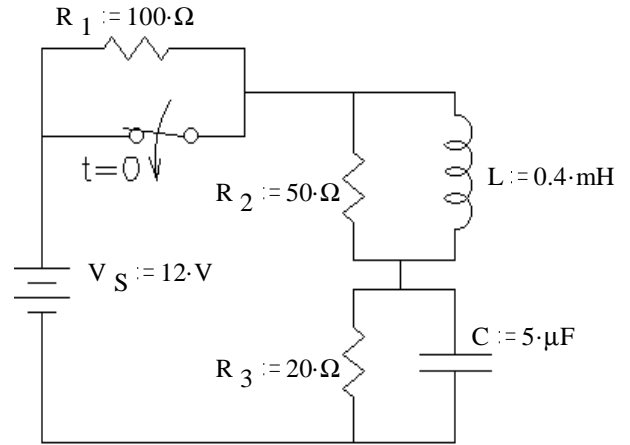

- b) Find the initial condition and initial slope of i_L that you would need to have in order to find all the constants in $i_L(t)$. Don't find $i_L(t)$ or it's constants, just the initial conditions.
 c) Find the initial condition and initial slope of v_C that you would need to have in order to find all the constants in $v_C(t)$. Don't find $v_C(t)$ or it's constants, just the initial conditions.

4. (24 pts) Assume that diodes D_1 and D_3 DO conduct. Assume that diode D_2 does NOT conduct.

- a) Find I_{R4} , V_{D2} , I_{R1} , & I_{D1} based on these assumptions. Stick with these assumptions even if your answers come out absurd.

$I_{R4} = ? \quad V_{D2} = ? \quad I_{R1} = ? \quad I_{D1} = ?$

$I_S = 50\text{-mA}$

Notes: The calculation of I_{R1} may be difficult unless you write a nodal equation or change the current source and R_2 into a Thevenin equivalent. Don't refer to nodal voltages unless you specify a ground.

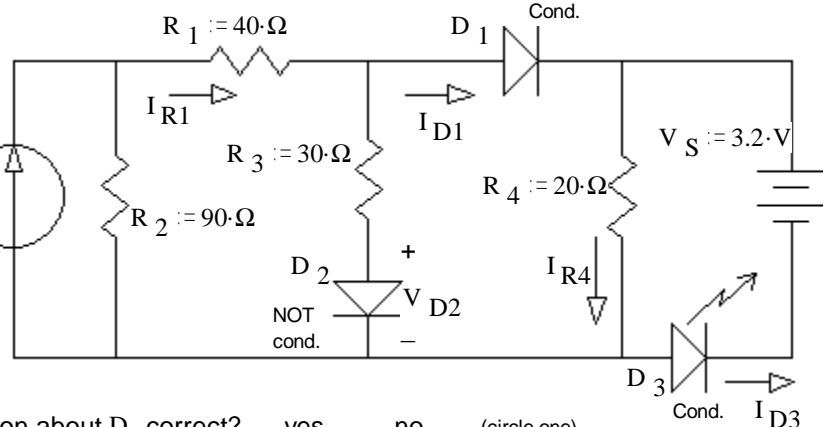

- b) Based on the numbers above, was the assumption about D_1 correct? yes no (circle one)
 How do you know? (Specifically show a value which is or is not within a correct range.)
 c) Was the assumption about D_2 correct? yes no (circle one) How do you know?
 d) Was the assumption about D_3 correct? yes no (circle one) How do you know?

Answers

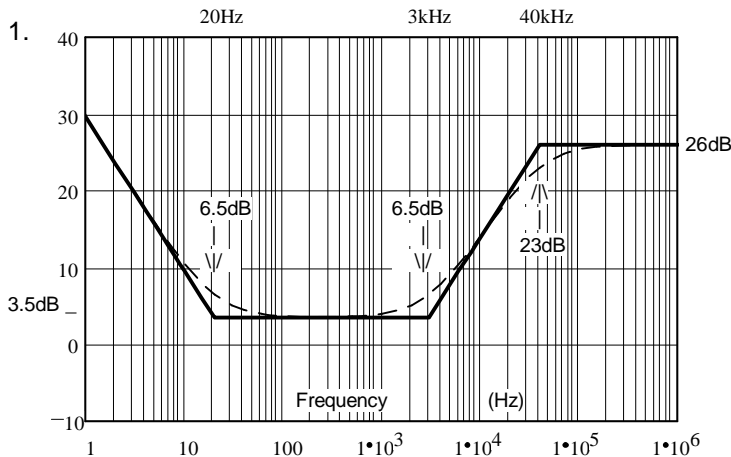

1. a) $\frac{8 \cdot K \cdot s \cdot (s + 2) \cdot (s + 80)}{s^2 + (100 - 8 \cdot K) \cdot s + 1600}$ b) 2.5 or 22.5
 c) Underdamped if: $2.5 < K < 22.5$
 d) $s = -2 \quad s = 0 \quad s = -80$
 3. a) 600·mA 12·V b) 100·mA $25000 \cdot \frac{A}{\text{sec}}$
 c) 2·V $40000 \cdot \frac{V}{\text{sec}}$
 4. a) 60·mA 1.9·V 20·mA 20·mA
 b) yes $I_{D1} = 20\text{-mA} > 0$
 c) no $V_{D2} = 1.9\text{-V} > 0.7\text{V}$
 d) yes $I_{D3} = 40\text{-mA} > 0$