

1. Use superposition to find I_3 . Circle your intermediate solutions on your paper. Your intermediate solutions show how much of I_3 is due to V_{S1} , and how much is due to V_{S2} .

The "node" at the black dot is node "a".
 V_a is a node voltage, referenced to ground.

$$V_a = V_{R3}$$

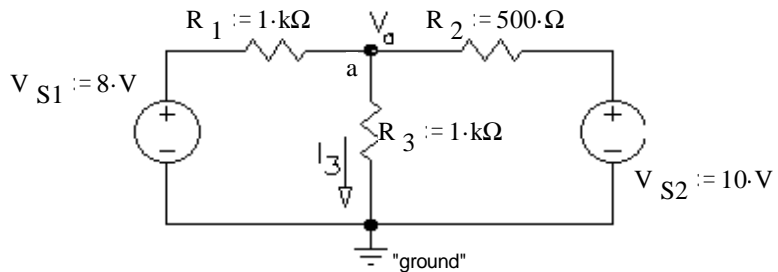

ECE 2210 / 00 homework DC4 p2

2. Use superposition to solve following problems:
Each problem asks for both a current and a voltage.
Clearly indicate your intermediate answers,
the grader will look for those.

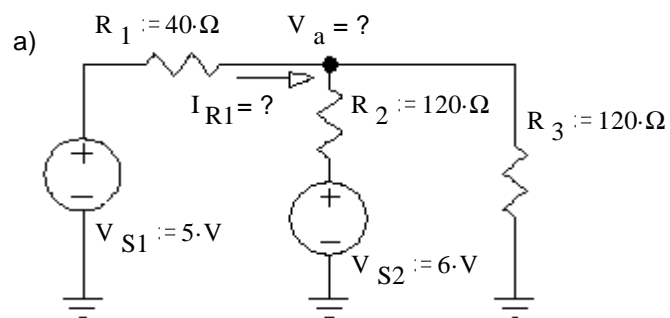

These are ground symbols. They are all connected together, although that connection is not explicitly shown.

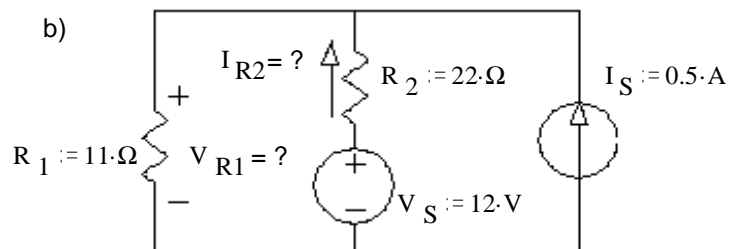

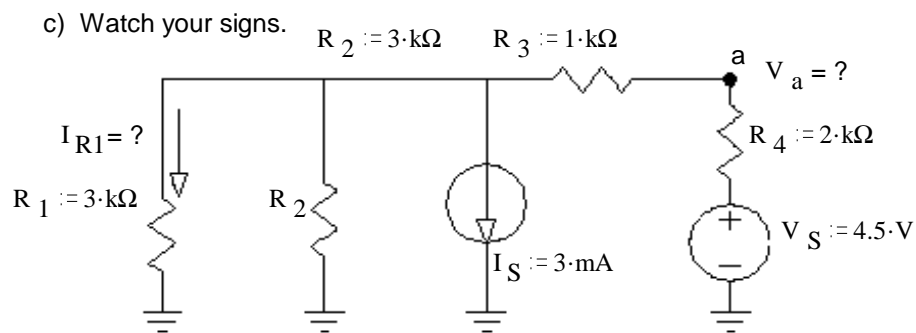

Answers 1. $2 \cdot \text{mA} + 5 \cdot \text{mA} = 7 \cdot \text{mA}$

2. a) $4.2 \cdot \text{V}$, $20 \cdot \text{mA}$ b) $7.67 \cdot \text{V}$, $197 \cdot \text{mA}$ c) $0.5 \cdot \text{V}$, $-0.5 \cdot \text{mA}$ **ECE 2210 / 00 homework DC4 p3**