

1. Assume that you know the values of all the resistors and sources and you want to find the circuit voltages.
 - a) Select a ground (reference) node and label it on the schematic (draw ground symbol).
 - b) Label other nodes **and** currents as necessary to perform nodal analysis.
 - c) How many simultaneous equations will you need to solve?
 - d) Write all the necessary equations in terms of the resistors, the sources, and the unknown nodes. Just write and circle the equations, do not try to simplify or solve them.

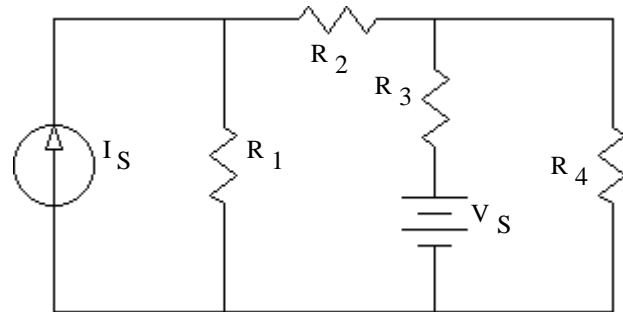

- e) Repeat parts a) through c) for this circuit.
Number of equations?

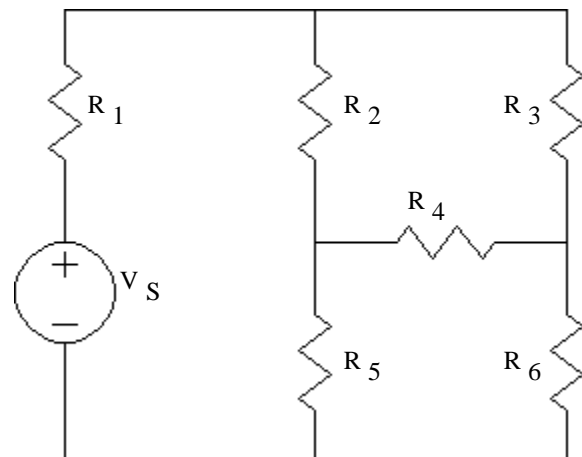

ECE 2210 / 00 homework DC7 p2

2. Use nodal analysis to find V_{R3} and then find I_{R2} .

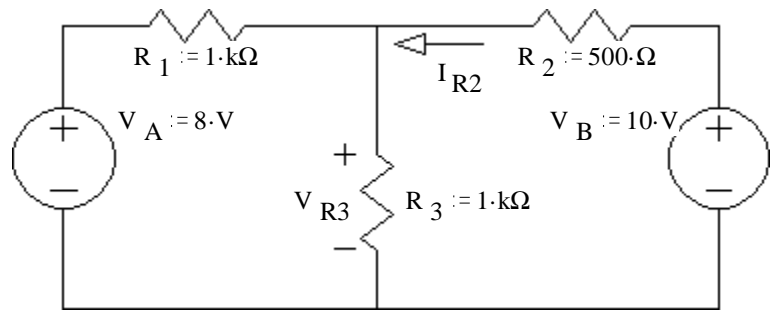

3. Use nodal analysis to find V_a , then find I_{R1} .

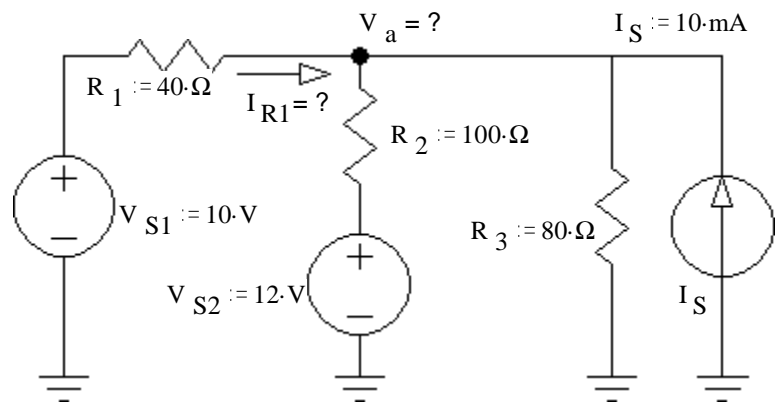

ECE 2210 / 00 homework DC7 p3

4. a) Select a ground and then use nodal analysis to find all the node voltages relative to that ground.

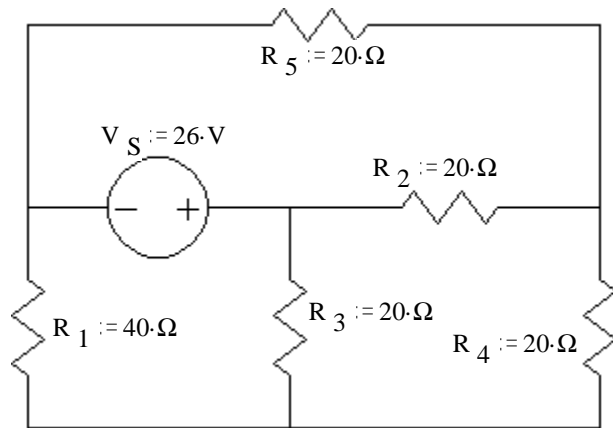

b) Your node voltages will depend on your selection of a reference node (ground) as well as your arbitrary node labels, so the grader won't look at these specifically. Use your node voltages to find the potential (voltage) across each resistor. Report the magnitude and polarity of each.

$V_{R1} =$

$V_{R2} =$

$V_{R3} =$

$V_{R4} =$

$V_{R5} =$

c) Were any of your current direction guesses in the wrong direction?

I guessed wrong on I_4 .

ECE 2210 / 00 homework DC7 p4

5. Use Nodal analysis to find V_a and V_b , then find I_{R1} .

hint: you may be able to eliminate one unknown node for the initial calculation.

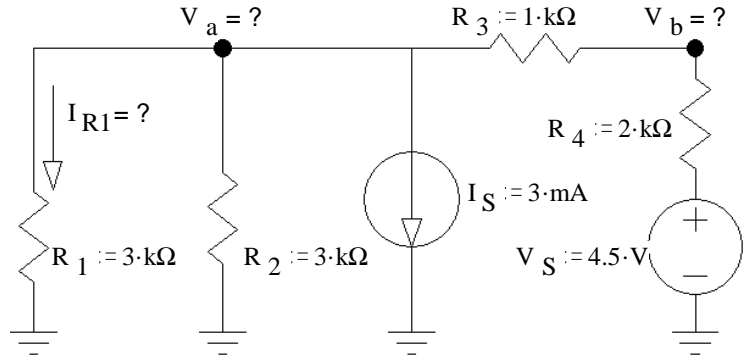

Answers

1. a) & b)
c) 2

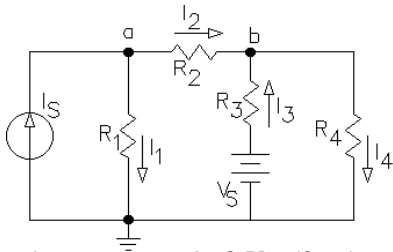

2. 7·V 6·mA 3. 8·V 50·mA

$$d) \quad I_S = \frac{V_a - 0}{R_1} + \frac{V_a - V_b}{R_2}$$

$$\frac{V_a - V_b}{R_2} + \frac{V_S - V_b}{R_3} = \frac{V_b - 0}{R_4}$$

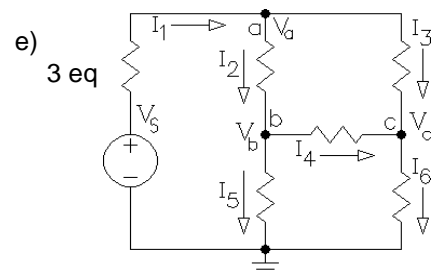

4. a) Answer will depend on your choice of ground, so check your answers to part b to see if you did part a) right.

b) R_1 16·V , + bottom , R_2 12·V , + left , R_3 10·V , + top , R_4 2·V , + bottom , R_5 14·V , + right

5. $V_a := -1.5·V$ $V_b := 0.5·V$ $I_{R1} := -0.5·mA$