

### Simple Model of a Real Source

Real sources are not ideal, but we will model them with two ideal components.

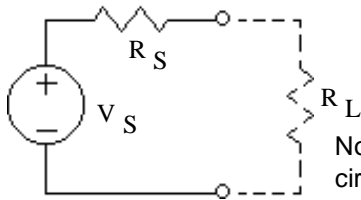
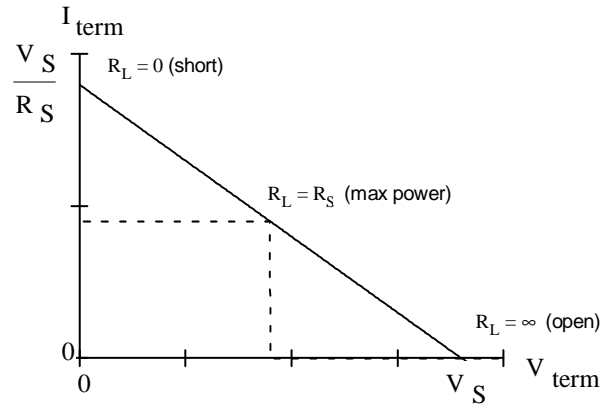
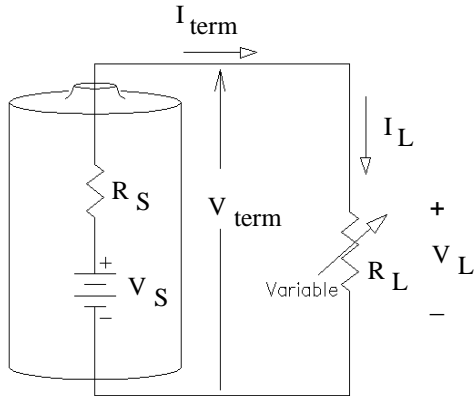

Note:  $R_L$  is NOT part of the Thévenin equivalent circuit and does not need to be shown.

### Thévenin Equivalent Circuit

The same model can be used for any combination of sources and resistors.

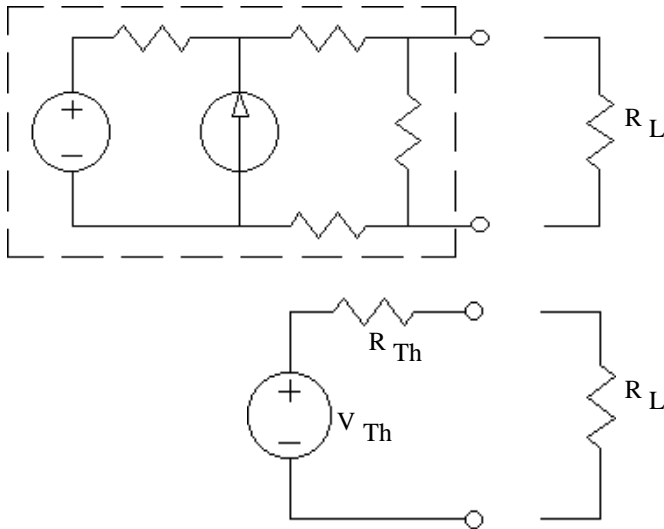

### Thévenin equivalent

To calculate a circuit's Thévenin equivalent:

- 1) Remove the load and calculate the open-circuit voltage where the load used to be.  
This is the Thévenin voltage ( $V_{Th}$ ).
- 2) Zero all the sources.  
(To zero a voltage source, replace it with a short. To zero a current source, replace it with an open.)
- 3) Compute the total resistance between the load terminals.  
(DO NOT include the load in this resistance.) This is the Thévenin source resistance ( $R_{Th}$ ).
- 4) Draw the Thévenin equivalent circuit and add your values.

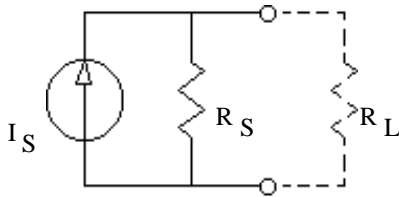
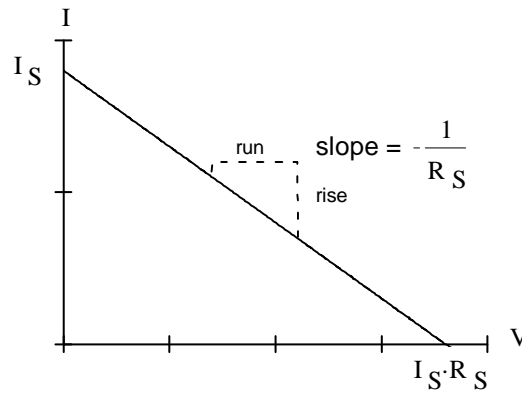
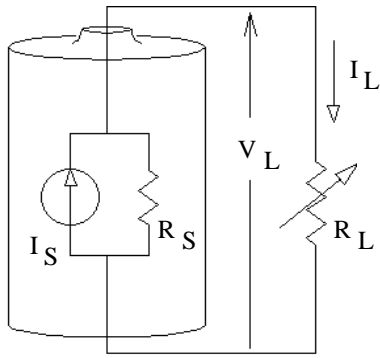

Note:  $R_L$  is not part of the Norton equivalent and does not need to be shown.

### Norton equivalent

To calculate a circuit's Norton equivalent:

- 1) Replace the load with a short (a wire) and calculate the short-circuit current in this wire.  
This is the Norton current ( $I_N$ ). Remove the short.
- 2) Zero all the sources.  
(To zero a voltage source, replace it with a short. To zero a current source, replace it with an open.)
- 3) Compute the total resistance between the load terminals.  
(DO NOT include the load in this resistance.) This is the Norton source resistance ( $R_N$ ).  
(Exactly the same as the Thévenin source resistance ( $R_{Th}$ )).
- 4) Draw the Norton equivalent circuit and add your values.

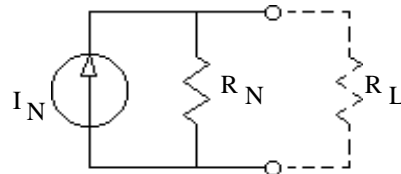

OR (the more common way)...

- 1) Find the Thévenin equivalent circuit.
- 2) Convert to Norton circuit, then >>>

$$R_N = R_{Th}$$

and

$$I_N = \frac{V_{Th}}{R_{Th}}$$

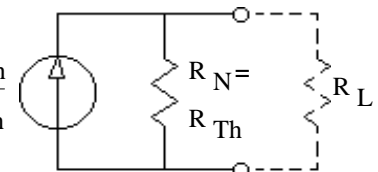

**Ex 1** Find the Thévenin equivalent:

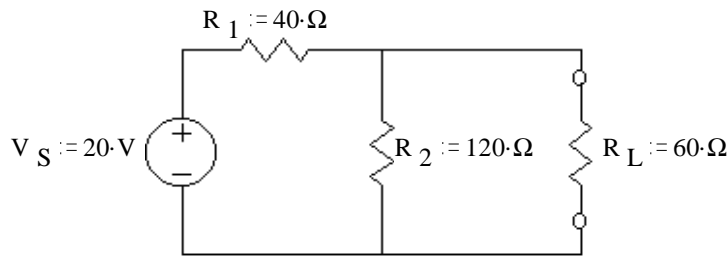

To calculate a circuit's Thévenin equivalent:

1) Remove the load and calculate the open-circuit voltage where the load used to be.

This is the Thévenin voltage ( $V_{Th}$ ).

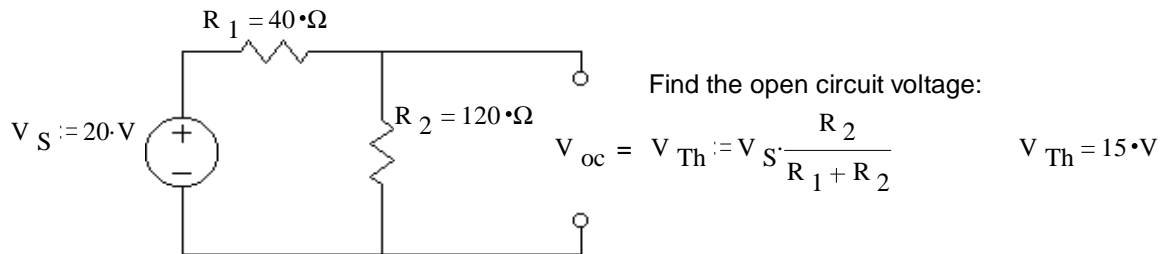

2) Zero all the sources.

(To zero a voltage source, replace it with a short. To zero a current source, replace it with an open.)

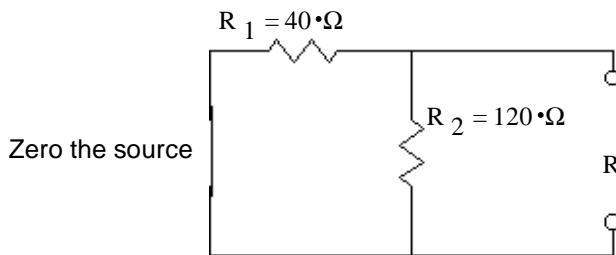

3) Compute the total resistance between the load terminals.

(DO NOT include the load in this resistance.)

This is the Thévenin source resistance ( $R_{Th}$ ).

Find the Thevenin resistance:

$$R_{Th} := \frac{1}{\frac{1}{R_1} + \frac{1}{R_2}} \quad R_{Th} = 30 \cdot \Omega$$

4) Draw the Thévenin equivalent circuit and add your values.

Thevenin equivalent circuit:

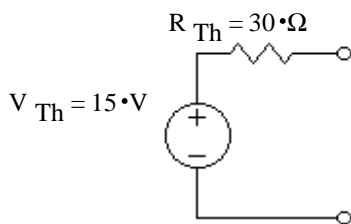

If the load were reconnected:

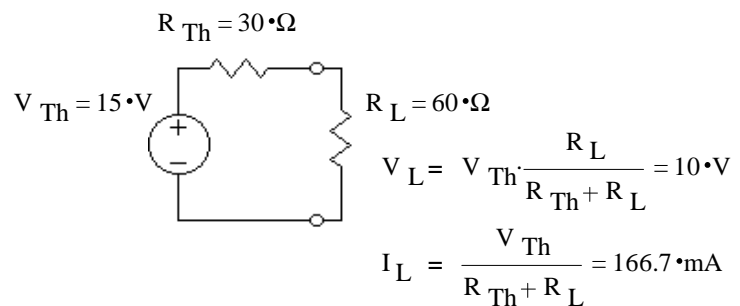

$$P_L = 10 \cdot V \cdot 166.7 \cdot \text{mA} = 1.667 \cdot W$$

b) Find the Norton equivalent circuit:

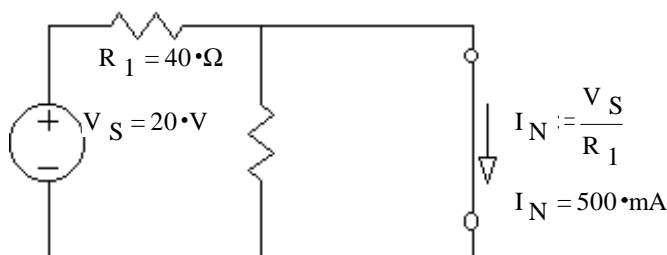

Norton equivalent circuit:

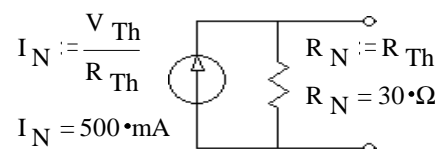

# ECE 2210 Thevenin notes p4

c) Show that the Thévenin circuit is indeed equivalent to the original at several values of  $R_L$ .

	Original Circuit		Thévenin Circuit	
$R_L$	$V_L$	$I_L$	$I_L$	$V_L$
$R_L := 0 \cdot \Omega$	0 V	$\frac{V_S}{R_1} = 500 \text{ mA}$	$\frac{V_{Th}}{R_{Th} + R_L} = 500 \text{ mA}$	$500 \text{ mA} \cdot 0 \cdot \Omega = 0 \text{ V}$

Using either numbers:  $P_L = V_L \cdot I_L = 0 \text{ W}$

$R_L := 10 \cdot \Omega$	$R_o := \frac{1}{\frac{1}{R_2} + \frac{1}{R_L}}$	$R_o = 9.231 \cdot \Omega$	$I_L := \frac{V_{Th}}{R_{Th} + R_L}$	$V_L := I_L \cdot R_L$
	$V_L = V_S \cdot \frac{R_o}{R_1 + R_o} = 3.75 \text{ V}$		$I_L = 375 \text{ mA}$	$V_L = 3.75 \text{ V}$

$I_L = \frac{V_L}{R_L} = 375 \text{ mA}$

Using either numbers:  $P_L = V_L \cdot I_L = 1.406 \text{ W}$

Repeat these calculations for a number of load resistors

$R_{L_i} :=$	$R_{o_i}$	$V_L = V_S \cdot \frac{R_{o_i}}{R_1 + R_{o_i}}$	$I_L = \frac{V_{L_i}}{R_{L_i}}$	$I_L = \frac{V_{Th}}{R_{Th} + R_{L_i}}$	$V_L = I_{L_i} \cdot R_{L_i}$	$P_{L_i}$
	$\Omega$	V	mA	mA	V	W
0·Ω	0	0	0	500	0	0
1·Ω	0.992	0.484	483.871	483.871	0.484	0.234
10·Ω	9.231	3.75	375	375	3.75	1.406
20·Ω	17.143	6	300	300	6	1.8
30·Ω	24	7.5	250	250	7.5	1.875 max
40·Ω	30	8.571	214.286	214.286	8.571	1.837
60·Ω	40	10	166.667	166.667	10	1.667
120·Ω	60	12	100	100	12	1.2
240·Ω	80	13.333	55.556	55.556	13.333	0.741
∞·Ω	120	15	0	0	15	0

## Plots

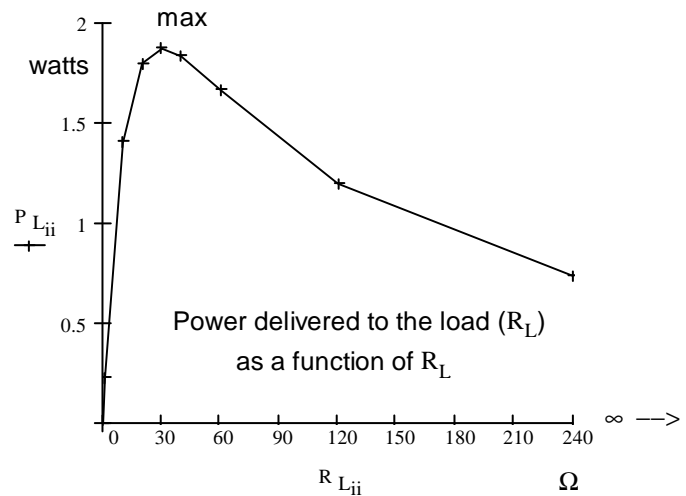
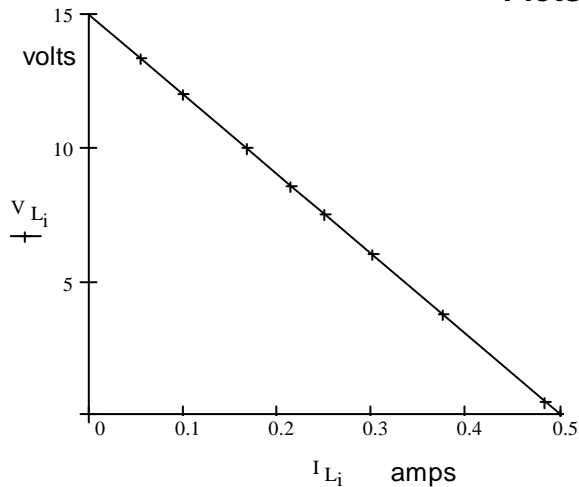

# ECE 2210 Thevenin notes p5

**Maximum power transfer** If I wanted to maximize the power dissipated by the load, what  $R_L$  would I choose?

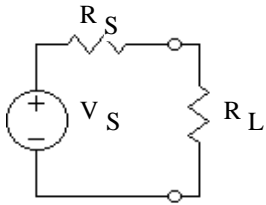

$$P_L = \frac{V_L^2}{R_L} = \left( \frac{R_L}{R_S + R_L} \cdot V_S \right)^2 \cdot \frac{1}{R_L} = \frac{R_L^2}{(R_S + R_L)^2} \cdot V_S^2 \cdot \frac{1}{R_L}$$

$$= \frac{R_L^2}{R_S^2 + 2 \cdot R_S \cdot R_L + R_L^2} \cdot V_S^2 \cdot \frac{1}{R_L} = \frac{R_L}{R_S^2 + 2 \cdot R_S \cdot R_L + R_L^2} \cdot V_S^2$$

$$= \frac{1}{\frac{R_S^2}{R_L} + 2 \cdot R_S + R_L} \cdot V_S^2$$

Next step would be to differentiate  $\frac{d}{dR_L} P_L(R_L)$ ,

set this equal to 0 and solve for  $R_L$  to find the maximum

Unfortunately this function is a pain to differentiate. What if we just differentiate the denominator and find its minimum, wouldn't that work just as well?

$$\frac{d}{dR_L} \left( \frac{R_S^2}{R_L} + 2 \cdot R_S + R_L \right) = -1 \cdot \frac{R_S^2}{R_L^2} + 0 + 1 = 0$$

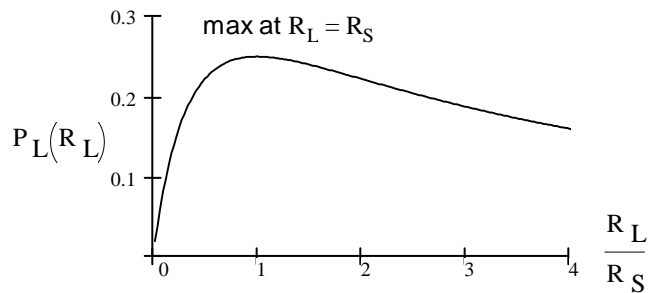

Maximum power transfer happens when:  $R_L = R_S$

Just what we saw in Example 1

This is rarely important in power circuitry, where there should be plenty of power and  $R_S$  should be small. It is much more likely to be important in signal circuitry where the voltages can be very small and the source resistance may be significant -- say a microphone or a radio antenna.

**All you need to remember is:**  $R_L = R_S$  to maximize the power dissipation in  $R_L$

**What about efficiency?**

$$\frac{P_L(R_L)}{P_S(R_L)} = \frac{I^2 \cdot R_L}{I^2 \cdot (R_S + R_L)} = \frac{R_L}{R_S + R_L}$$

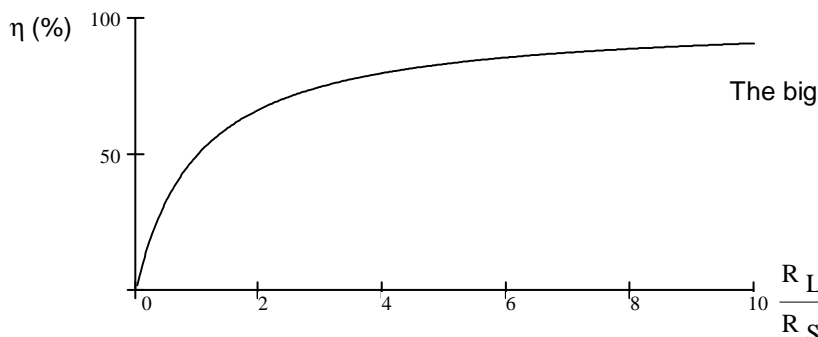

The bigger  $R_L$  is, the higher the efficiency.

**Ex 2** a) Find and draw the Thévenin equivalent circuit.

ECE 2210 Thevenin notes p6

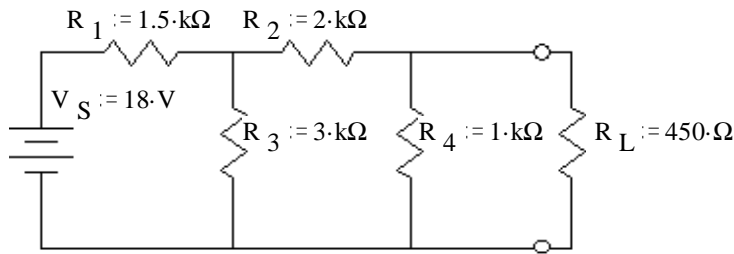

Find the open circuit voltage:

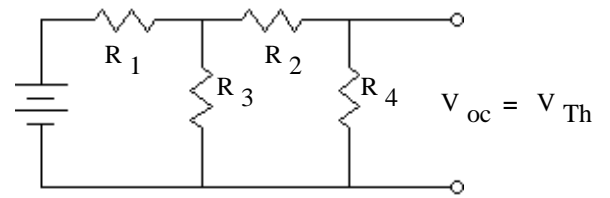

First do some simplification:

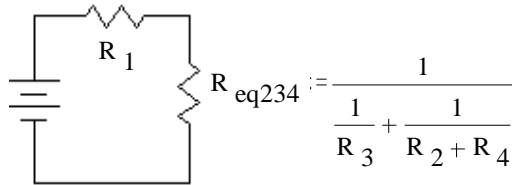

$$R_{eq234} = 1.5 \cdot k\Omega$$

$$V_{234} := \frac{R_{eq234}}{R_1 + R_{eq234}} \cdot V_S$$

$$V_{234} = 9 \cdot V$$

Divide this voltage between  $R_2$  and  $R_4$ :

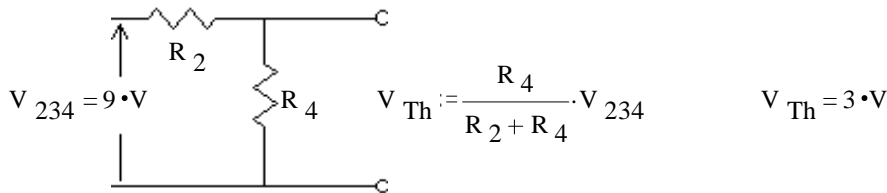

$$V_{Th} := \frac{R_4}{R_2 + R_4} \cdot V_{234}$$

$$V_{Th} = 3 \cdot V$$

Find the Thévenin resistance:

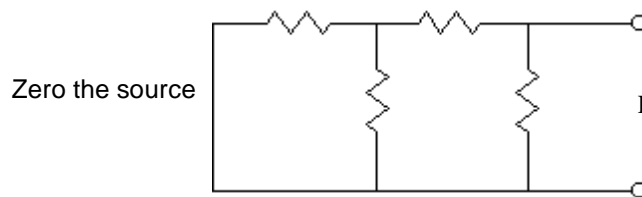

Zero the source

$$R_{Th} := \frac{1}{\frac{1}{R_4} + \frac{1}{R_2 + \left(\frac{1}{\frac{1}{R_1} + \frac{1}{R_3}}\right)}}$$

$$R_{Th} = 750 \cdot \Omega$$

Thévenin equivalent circuit:

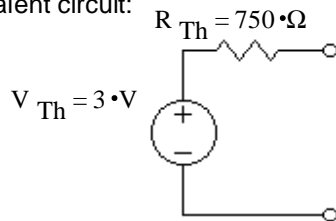

If the load were reconnected:

$$V_L := V_{Th} \cdot \frac{R_L}{R_{Th} + R_L}$$

$$V_L = 1.125 \cdot V$$

$$I_L := \frac{V_{Th}}{R_{Th} + R_L}$$

$$I_L = 2.5 \cdot mA$$

b) Find and draw the Norton equivalent circuit.

$$I_N := \frac{V_{Th}}{R_{Th}}$$

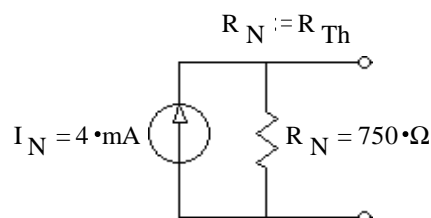

# ECE 2210 Thevenin notes p7

c) Use your Norton equivalent circuit to find the current through the load.

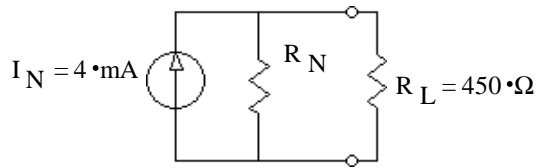

$$I_L := \frac{\frac{1}{R_L}}{\left(\frac{1}{R_N} + \frac{1}{R_L}\right)} \cdot I_N \quad I_L = 2.5 \text{ mA}$$

$$V_L := I_L \cdot R_L \quad V_L = 1.125 \text{ V}$$

same as above

d) What value of  $R_L$  would result in the maximum power delivery to  $R_L$ ?

For maximum power transfer  $R_L = R_{Th} = 750 \text{ ohms}$

e) What is the maximum power transfer?

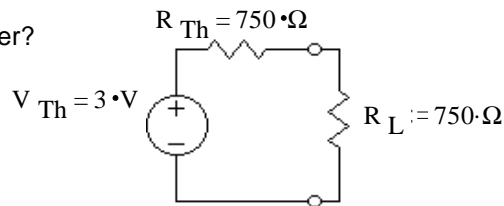

$$V_L := \frac{V_{Th}}{2}$$

$$P_L = \frac{V_L^2}{R_L} = 3 \text{ mW}$$

**Ex 3** a) Find and draw the Thévenin & Norton equivalent circuits.

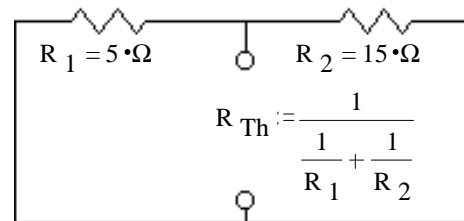
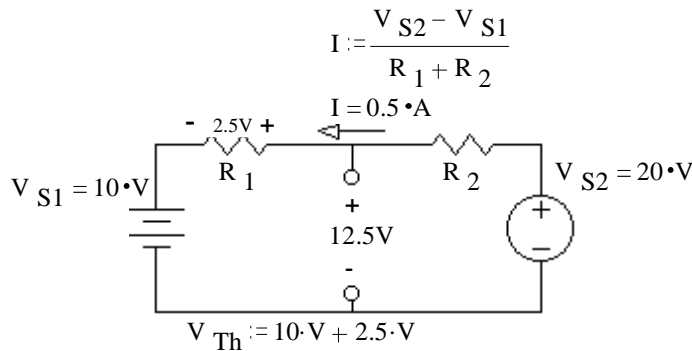
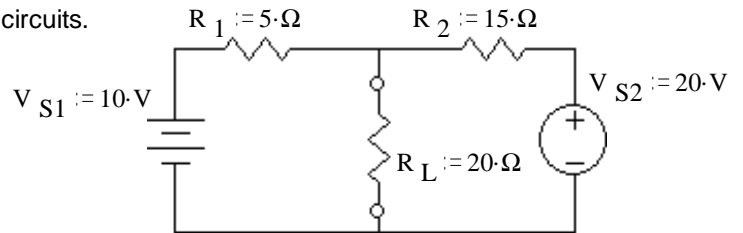

$$R_{Th} = 3.75 \text{ ohms}$$

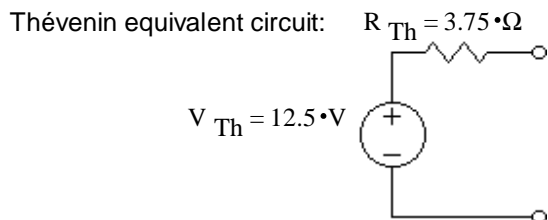

Norton equivalent circuit:

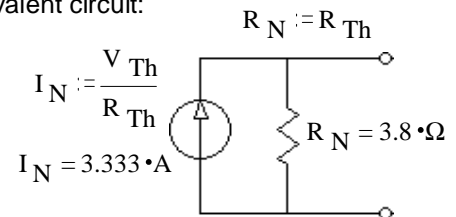

b) Use your Thévenin equivalent circuit to find the voltage across the load.

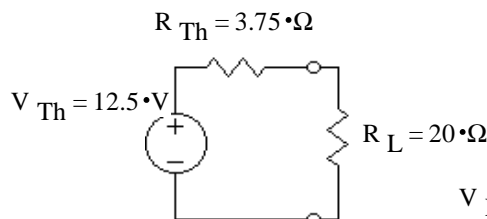

$$V_L = \frac{R_L}{R_{Th} + R_L} \cdot V_{Th} = 10.526 \text{ V}$$

**Ex 4** a) Find and draw the Thévenin & Norton equivalent circuits.

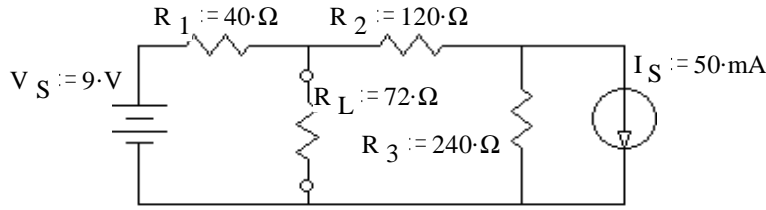

Use superposition to find  $V_{Th}$ .

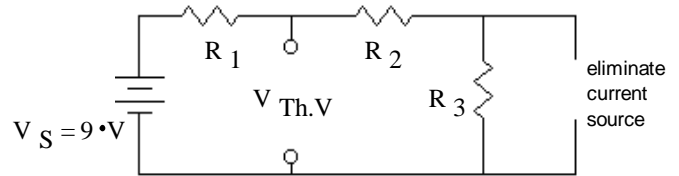

$$V_{Th,V} := \frac{R_2 + R_3}{R_1 + R_2 + R_3} \cdot V_S$$

$$V_{Th,V} = 8.1 \cdot V$$

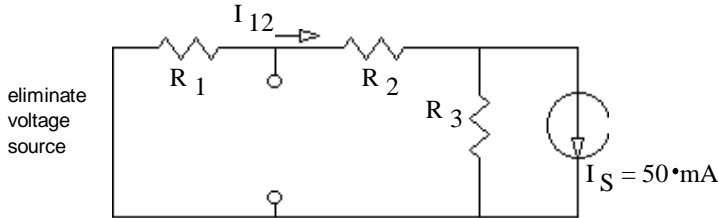

eliminate voltage source

$$\text{current divider: } I_{12} := \frac{\frac{1}{R_1 + R_2}}{\frac{1}{R_1 + R_2} + \frac{1}{R_3}} \cdot I_S \quad I_{12} = 30 \cdot \text{mA}$$

$$V_{Th,I} := -I_{12} \cdot R_1 \quad V_{Th,I} = -1.2 \cdot V$$

$$V_{Th} := V_{Th,V} + V_{Th,I} \quad V_{Th} = 6.9 \cdot V$$

Find the Thévenin resistance

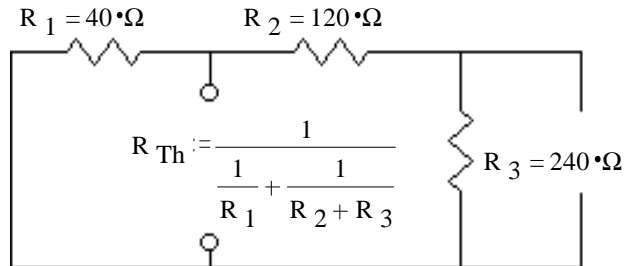

Thévenin equivalent circuit:

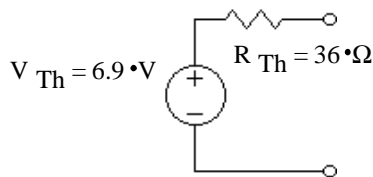

Put the load back on

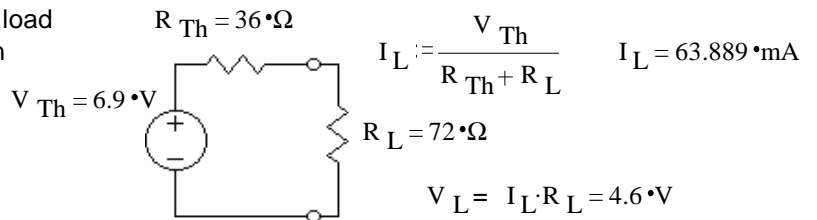

Norton equivalent circuit:

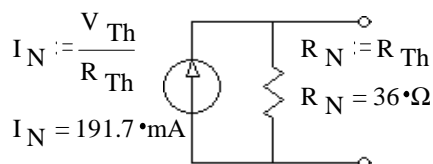



## ECE 2210 Thevenin notes p9

**Ex 5** A NiCad Battery pack is used to power a cell phone. When the phone is switched on the battery pack voltage drops from 4.80 V to 4.65 V and the cell phone draws 50 mA.  $V_S := 4.80 \cdot V$   $V_{50} := 4.65 \cdot V$

- a) Draw a simple, reasonable model of the battery pack using ideal parts.  
Find the value of each part.

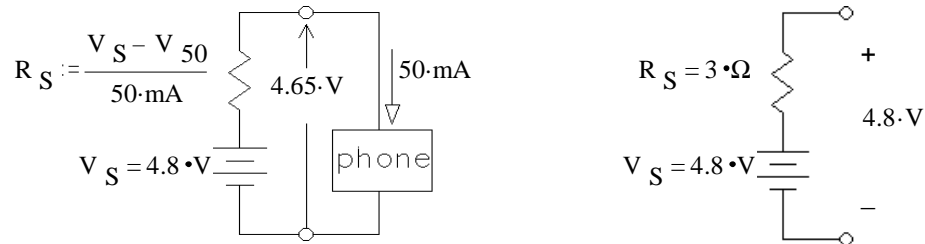

- b) The cell phone is used to make a call. Now it draws 300 mA.  
What is the battery pack voltage now?

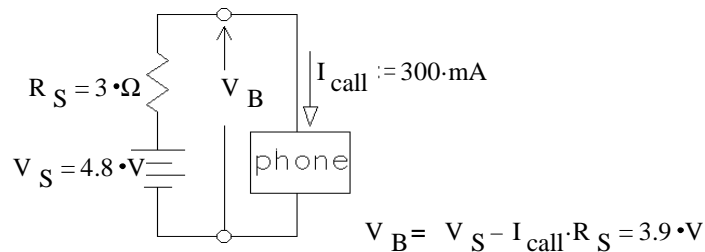

- c) The battery pack is placed in a charger. The charger supplies 5.10 V. How much current flows into the battery pack?

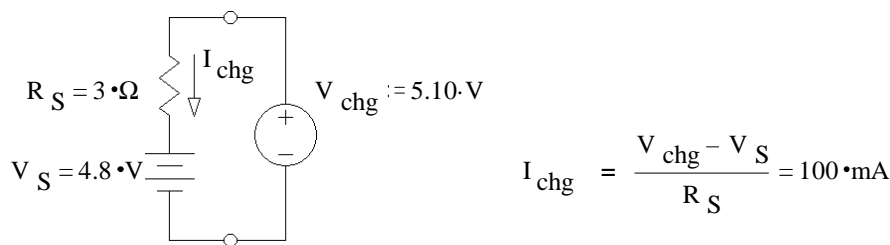

**Ex 6** Consider the circuit at right.

- a) What value of load resistor ( $R_L$ ) would you choose if you wanted to maximize the power dissipation in that load resistor.

$$R_L := R_S \quad R_L = 8 \cdot \Omega$$

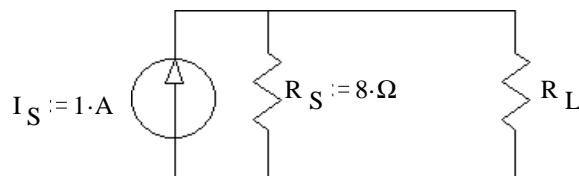

- b) With that load resistor ( $R_L$ ) find the power dissipation in the load.

$$I_L := \frac{I_S}{2} \quad P_L = I_L^2 \cdot R_L = 2 \cdot W$$

ECE 2210 Thevenin notes p10

Ex 7

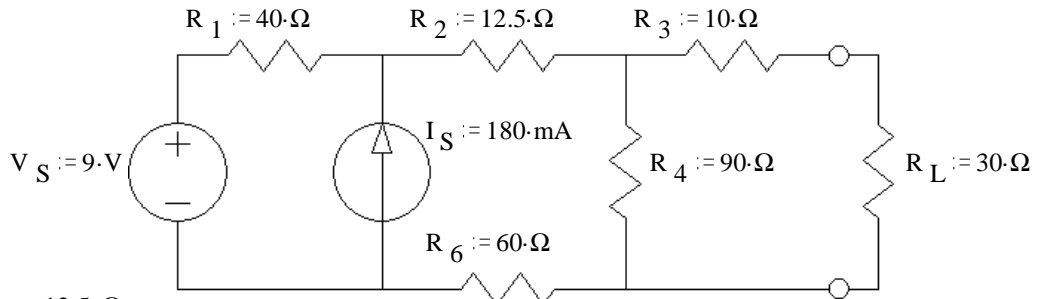

Use superposition to find  $V_{Th}$ .

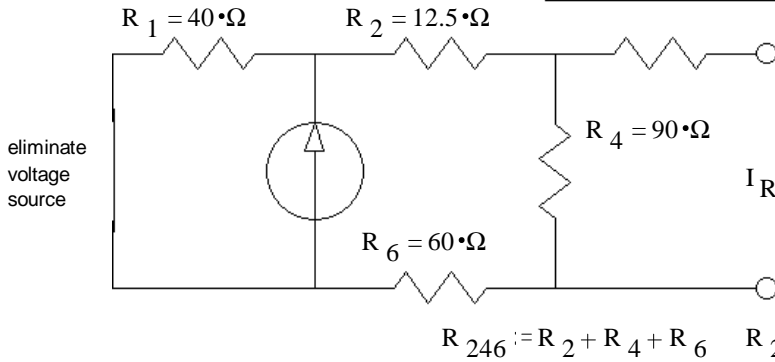

current divider:

$$I_{R4} := \frac{\frac{1}{R_2 + R_4 + R_6} \cdot I_S}{\frac{1}{R_2 + R_4 + R_6} + \frac{1}{R_1}} \quad I_{R4} = 35.556 \text{ mA}$$

$$V_{Th,I} := I_{R4} \cdot R_4 \quad V_{Th,I} = 3.2 \text{ V}$$

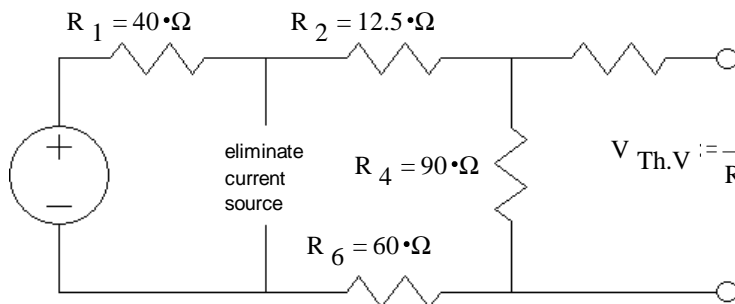

$$V_{Th,V} := \frac{R_4}{R_1 + R_2 + R_4 + R_6} \cdot V_S \quad V_{Th,V} = 4 \text{ V}$$

$$V_{Th} := V_{Th,V} + V_{Th,I} \quad V_{Th} = 7.2 \text{ V}$$

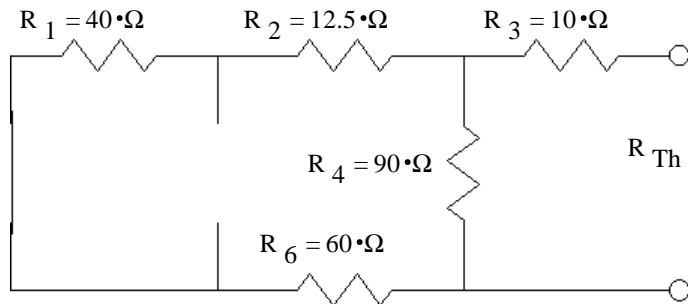

$$R_{Th} := \frac{1}{\frac{1}{R_4} + \frac{1}{R_1 + R_2 + R_6}} + R_3 \quad R_{Th} = 60 \Omega$$

Thévenin equivalent circuit:

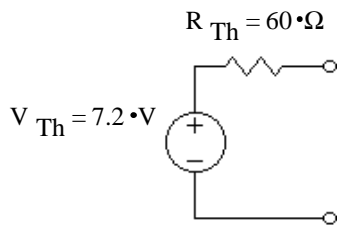

Put the load back on

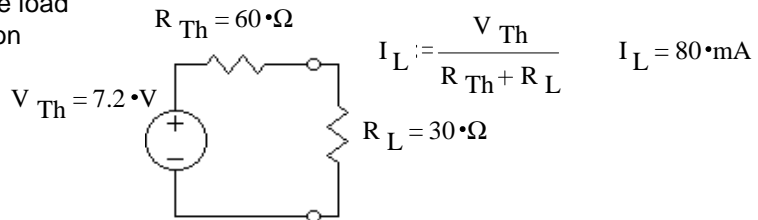

$$V_L = I_L \cdot R_L = 2.4 \text{ V}$$

Norton equivalent circuit:

