

1. Fill in the blanks in the circuits below and on the next page. Assume that the motor can be modeled with a  $20\ \Omega$  resistor and that transistor  $\beta$ 's are 25 (a very conservative estimate).

A. Stolp

$R_{mot} := 20\ \Omega$

$\beta := 25$

a)

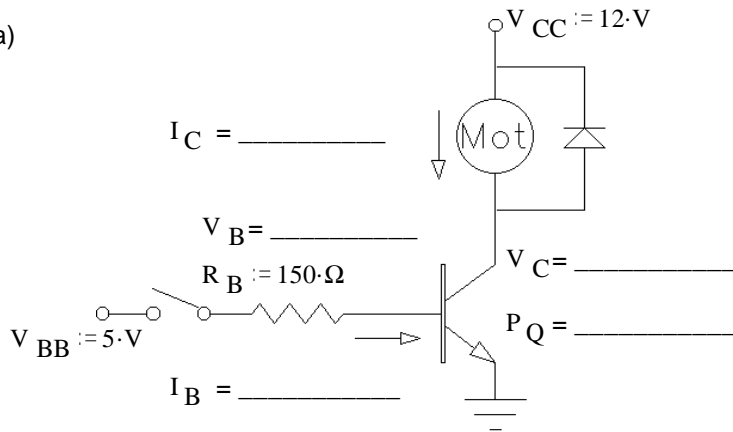

b)

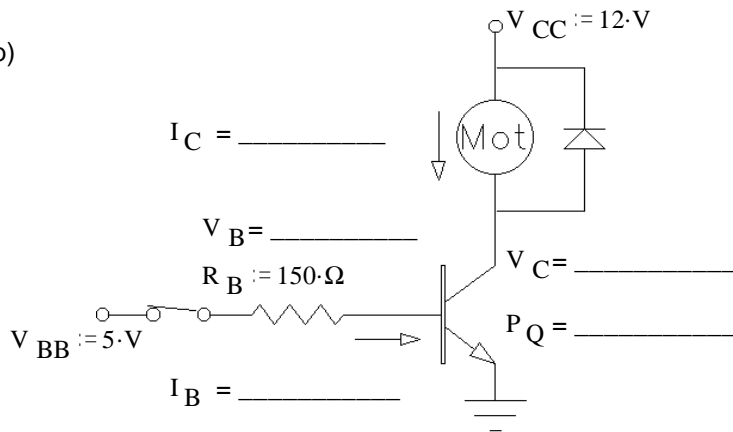

c)

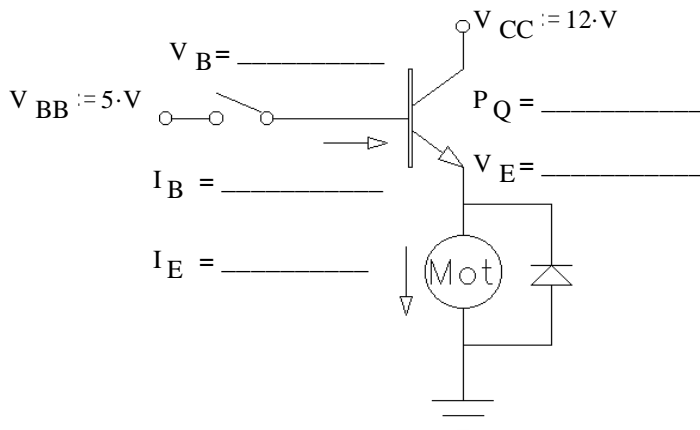

1. Fill in the blanks in the circuits below and on the next page. Assume that the motor can be modeled with a  $25\ \Omega$  resistor and that transistor  $\beta$ 's are 25 (a very conservative estimate). A. Stolp b  
 $R_{mot} := 20\ \Omega$   $\beta := 25$

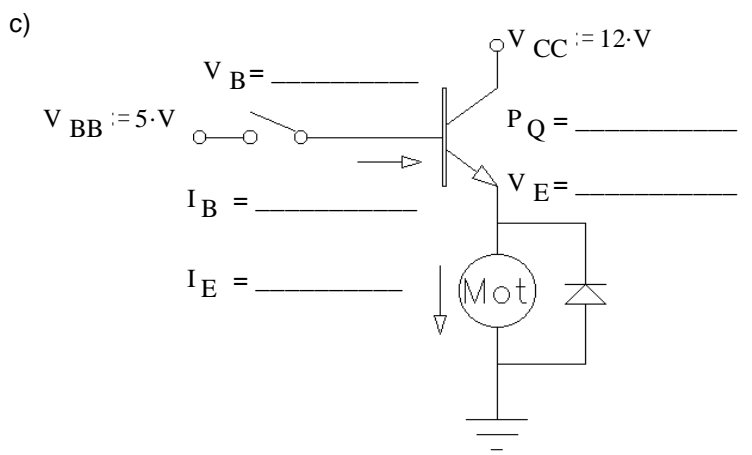
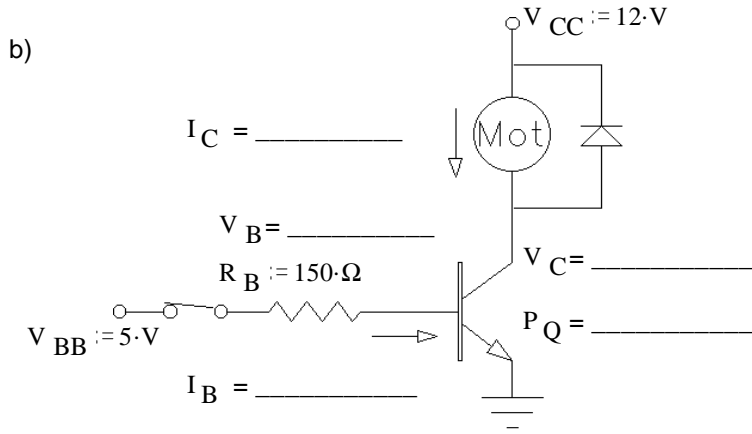
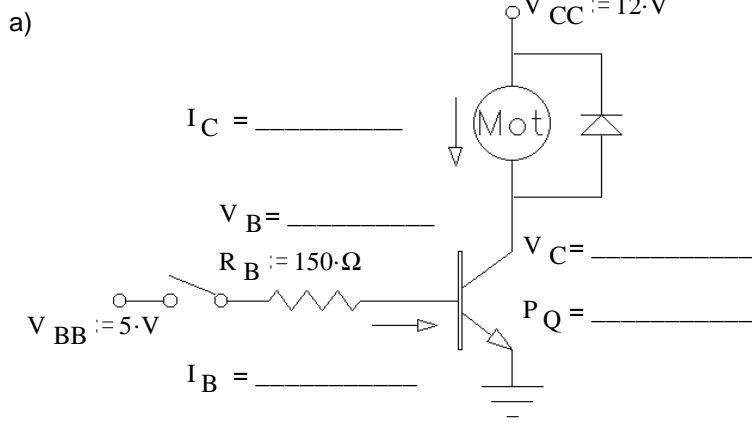

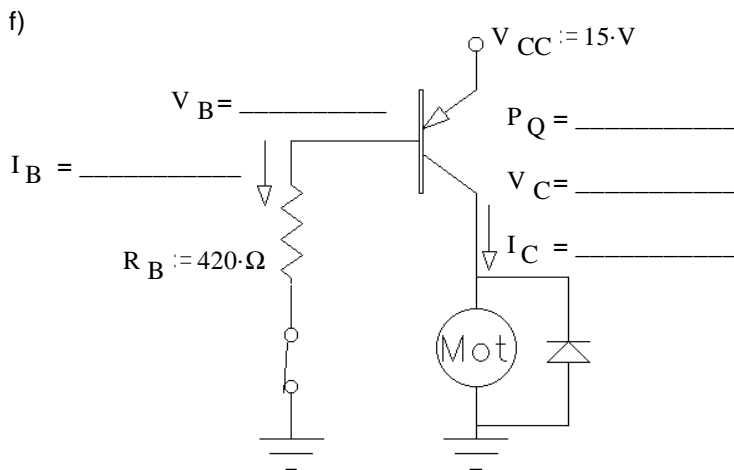
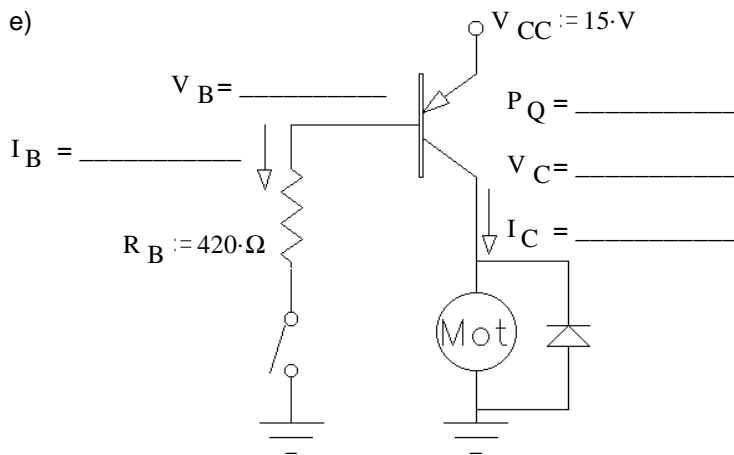
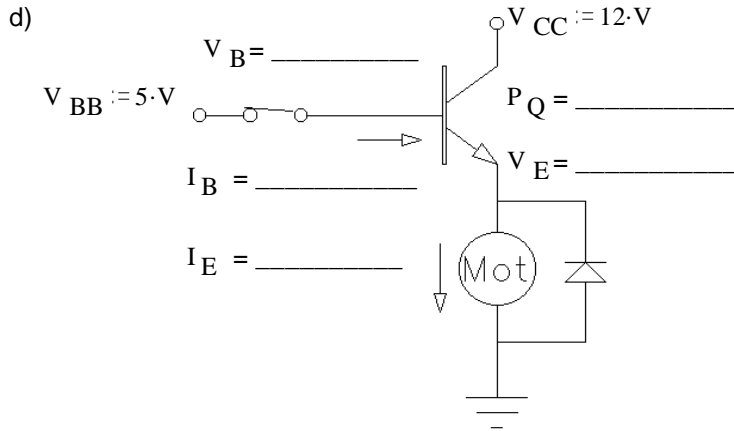

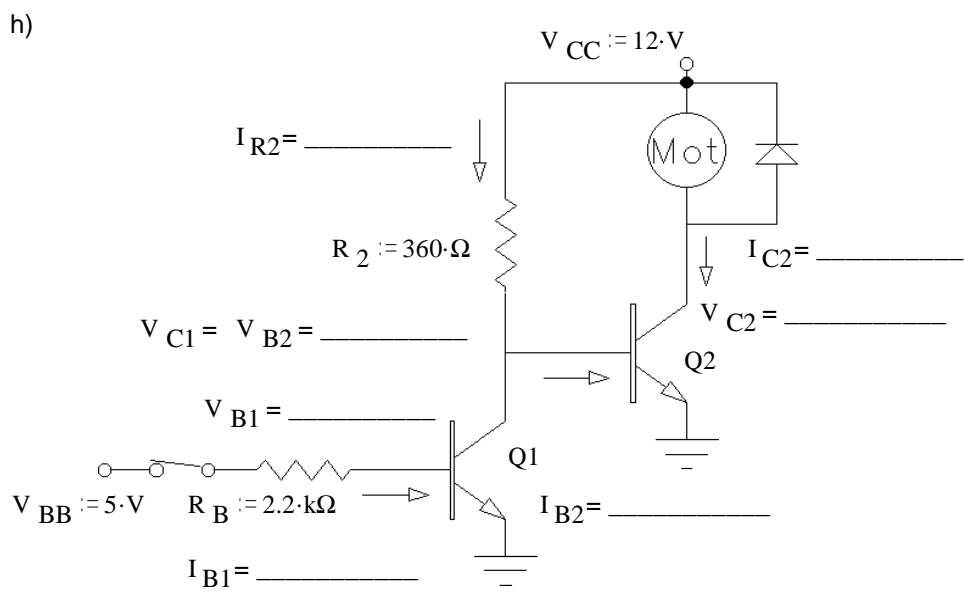
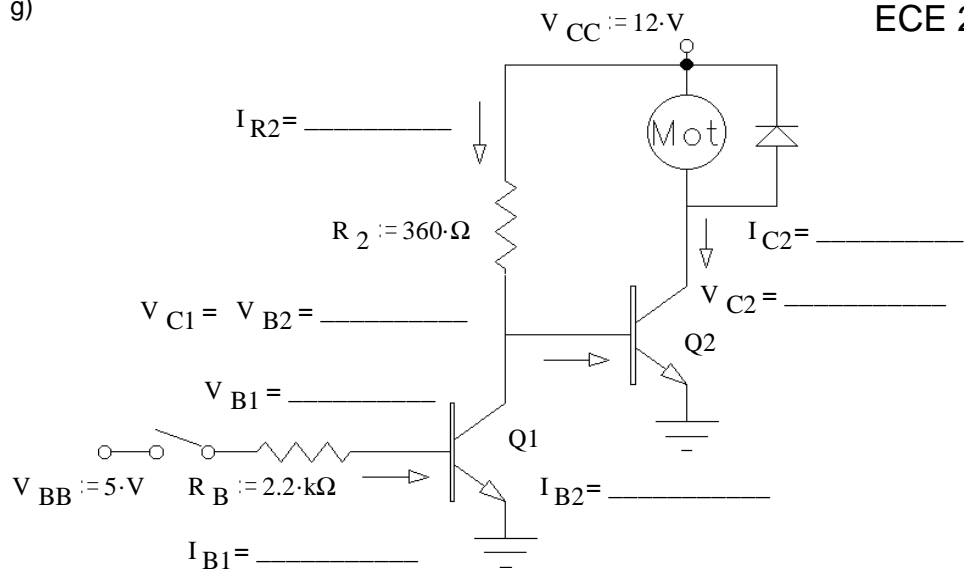

2. In problem 1b, What is the largest value that  $R_B$  could be and still keep the transistor in saturation?
  
3. In problem 1f, What is the largest value that  $R_B$  could be and still keep the transistor in saturation?

# ECE 2210 homework # 24 p4

4. a)  $\beta := 40$  Assume the transistor is in the active region, find  $I_C$ , and  $V_{CE}$  and  $P_Q$ .

$I_C = ?$        $V_{CE} = ?$        $P_Q = ?$

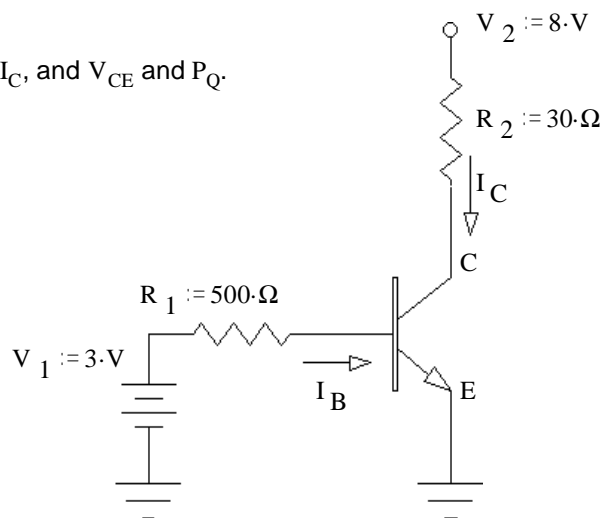

b) Was the transistor actually operating in the active region?    yes    no    circle one  
How do you know? (Specifically show a value which is or is not within a correct range.)

c)  $\beta := 40$  find the maximum value of  $R_1$ , so that the transistor will be in saturation.

d)  $R_1 = 500 \cdot \Omega$  and can't be changed, find the minimum value of  $\beta$ , so that the transistor will be in saturation.

# ECE 2210 homework # 24 p5

5. A transistor is used to control the current flow through an inductive load (in the dotted box, it could be a relay coil or a DC motor).

a) Assume the transistor is in saturation (fully on) and that switch has been closed for a long time. What is the load current?

$$I_C = ?$$

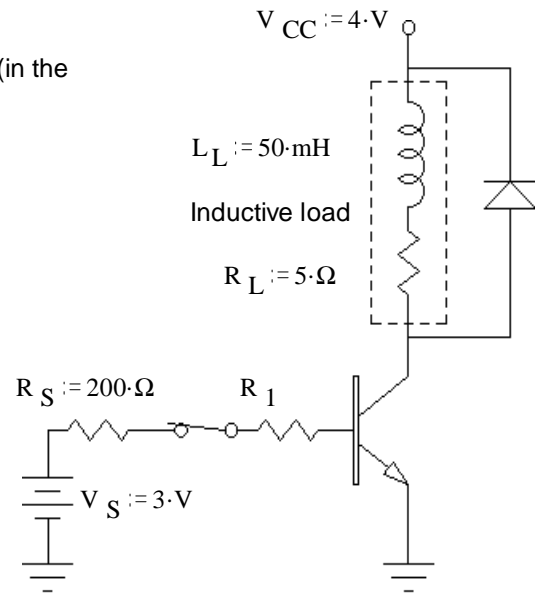

b)  $\beta := 80$  find the maximum value of  $R_1$ , so that the transistor will be in saturation.

Use this  $R_1$  for the rest of the problem.

c) You got a bad transistor.  $\beta := 40$  Find the new  $I_C$ , and  $V_{CE}$  and  $P_Q$ .

$$I_C = ? \quad V_{CE} = ? \quad P_Q = ?$$

The power dissipation was too high for the transistor and it burned out. You replace the transistor with a new one that has  $\beta \geq 80$

d) The diode in this circuit conducts a significant current: (circle one)

- A) never.
- B) when the switch opens.
- C) whenever the switch is open.
- D) when the switch closes.
- E) whenever the switch is closed.
- F) always.

e) The switch is opened and closed a few times. What is the maximum diode current you expect. (Answer 0 if it never conducts.)

# ECE 2210 homework # 24 p6

6. A power transistor is used to control the current flow through an inductive load (in the dotted box, it could be a relay coil or a DC motor). The input to the base of the transistor is shown below ( $v_{in}$ ). The time constant of the RL load is much shorter than the on or off times of  $v_{in}$ . When the transistor conducts, consider  $V_{CE} = 0.2V$ .

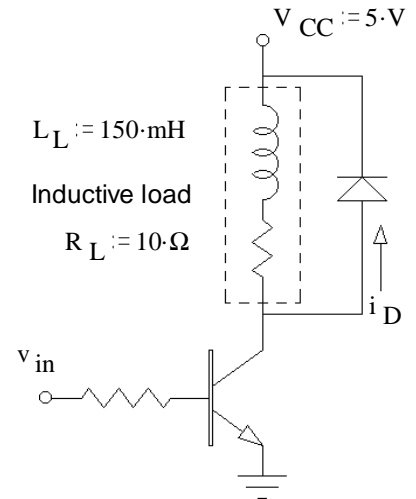

a) what is the maximum load current you expect.

b) If the diode ever conducts, what is the maximum diode current you expect.

c) If the diode ever conducts, sketch the approximate diode waveform below.

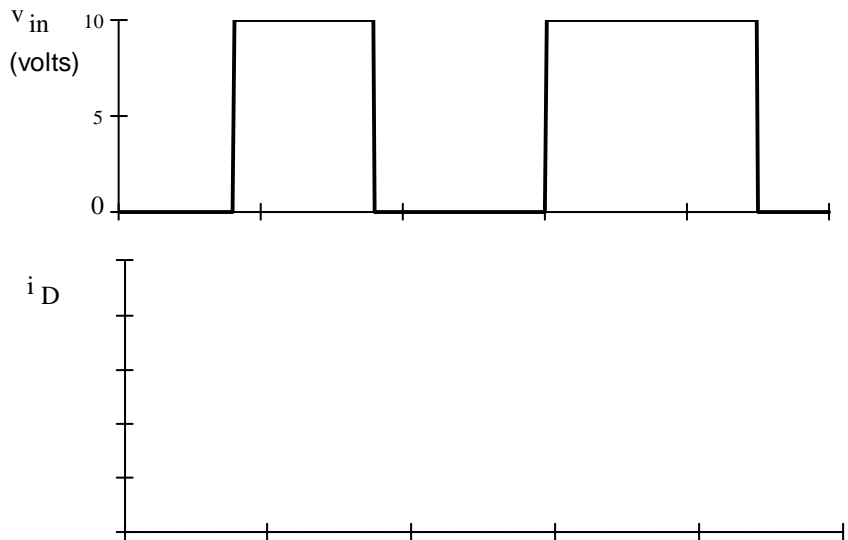

## Answers

1. a)  $V_B = 0V$ ,  $I_B = 0mA$ ,  $V_C = 12V$ ,  $I_C = 0mA$ ,  $P_Q = 0mW$   
 b)  $V_B = 0.7V$ ,  $I_B = 28.7mA$ ,  $V_C = 0.2V$ ,  $I_C = 590mA$ ,  $P_Q = 118mW$   
 c)  $V_B = 0V$ ,  $I_B = 0mA$ ,  $V_E = 0V$ ,  $I_E = 0mA$ ,  $P_Q = 0mW$       d)  $V_B = 5V$ ,  $V_E = 4.3V$ ,  $I_E = 215mA$ ,  
 d, con't)  $I_B = 8.3mA$ ,  $P_Q = 1.59W$ , **OR:**  $I_B = 8.6mA$ ,  $P_Q = 1.66W$  if you neglect  $I_B$  contribution to  $I_E$ .  
 e)  $V_B = 15V$  (emitter-base junction is not a perfect "open" even when  $V_{EB} < 0.7V$ ),  $I_B = 0mA$ ,  $V_C = 0V$ ,  
 $I_C = 0mA$ ,  $P_Q = 0mW$       f)  $V_B = 14.3V$ ,  $I_B = 34mA$ ,  $V_C = 14.8V$ ,  $I_C = 740mA$ ,  $P_Q = 148mW$   
 g)  $V_{B1} = 0V$ ,  $I_{B1} = 0mA$ ,  $V_{C1} = V_{B2} = 0.7V$ ,  $I_{B2} = I_{R2} = 31.4mA$ ,  $V_{C2} = 0.2V$ ,  $I_{C2} = 590mA$   
 h)  $V_{B1} = 0.7V$ ,  $I_{B1} = 1.95mA$ ,  $V_{C1} = V_{B2} = 0.2V$ ,  $I_{R2} = I_{C1} = 32.8mA$ ,  $I_{B2} = 0mA$ ,  $I_{C2} = 0mA$ ,  $V_{C2} = 12V$
2. 182  $\Omega$       3. 483  $\Omega$
4. a) 184 mA    2.48 V    0.456 W    b) yes     $V_{CE} = 2.5V > 0.2V$     c) 354  $\Omega$     d) 56.5
5. a) 0.76 A    b) 42.1  $\Omega$   
 c) 380 mA    2.1 V    0.798 W  
 d) B    e) 0.76 A
6. a) 0.48 A    b) 0.48 A    c) at right

