

Solution

Problem 1 (10 points)

$V_2 = 0.1m \sin(\omega t)$ and β can vary from 20 to 200. The circuit shown below is suppose to amplify but does not. You expect the output at V_o to amplify V_2 . When you are testing the circuit, you find that it does not amplify. Explain why it does not and what exact resistor can be changed to allow it to amplify. I_1 is not an ideal current source and can have a voltage drop across it.

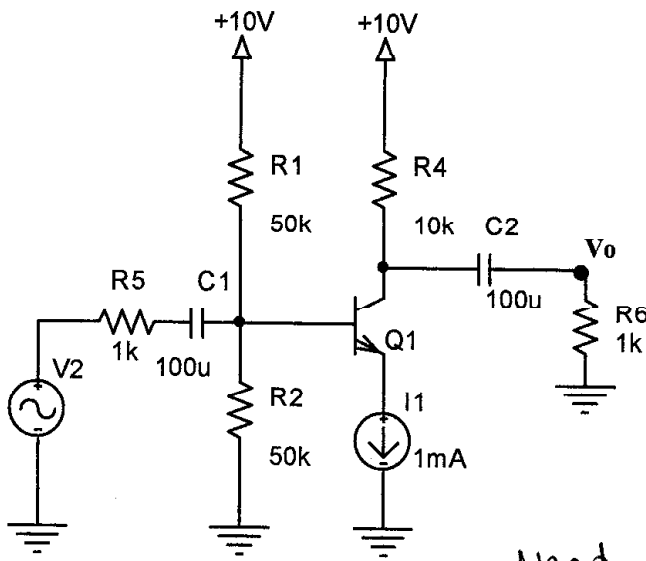

$$V_B = 5V$$
$$V_C \approx 0V$$

$$\underline{V_C < V_B}$$

Not in active region. Therefore, it will not amplify.

Need to decrease R_4 so that $V_C > V_B > V_E$

Problem 2 (35 points)

Use $|V_{BE}|=0.7$, $\beta=100$, $V_T=25mV$ (V_2 is an ac source).

- Find the DC values for the following
 - a. I_{E1} (15 points)
 - b. I_{C1} (3 points)
 - c. V_{E1} (6 points)
 - d. V_{C1} (6 points)
 - e. V_{B1} (5 points)

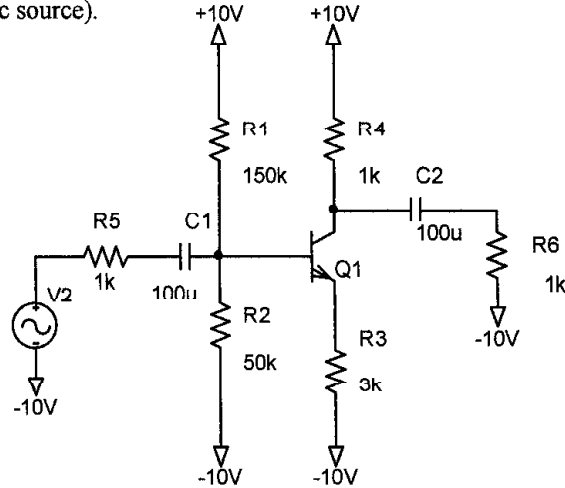

Thevenin of R_1 and R_2 :

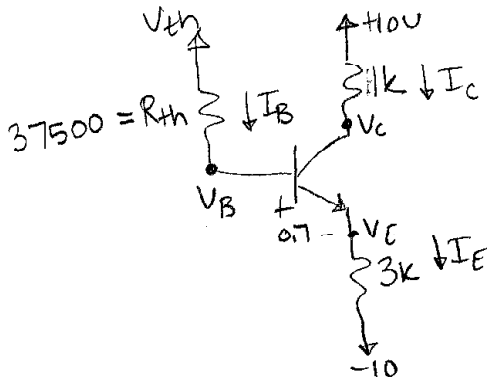

$V_{th} \Rightarrow$ (Thevenin is calculated by finding open-circuit voltage)

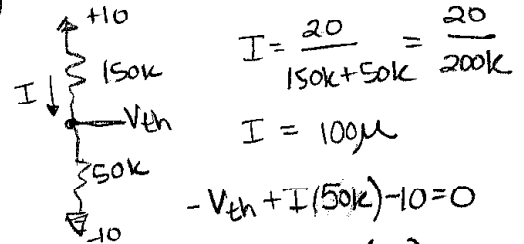

$$I = \frac{20}{150k + 50k} = \frac{20}{200k}$$

$$I = 100\mu$$

$$-V_{th} + I(50k) - 10 = 0$$

$$V_{th} = 100\mu(50k) - 10$$

$$V_{th} = -5V$$

$R_{th} \Rightarrow$ (short sources and find resistive network) $\Rightarrow 150k \parallel 50k$

$$-V_{th} + I_B(37500) + 0.7 + I_E(3k) - 10 = 0$$

$$I_B = \frac{I_E}{\beta + 1}$$

| | |
|-----------------------------|------------------------------------|
| $I_E = 1.3mA$ | $V_E = I_E(3k) - 10 = -6.1$ |
| $I_C = \alpha I_E = 1.26mA$ | $V_B = V_{th} - I_B(R_{th}) = 5.4$ |
| $I_B = 12.7\mu$ | $V_C = 10 - I_C(1k) = 8.71$ |

$$V_C > V_B > V_E$$

Problem 3 (55 points)

Use $|V_{BE}|=0.7$, $\beta=20$, $V_T=25mV$ (V_s is an ac source), ignore r_o .

This small-signal model circuit is drawn below. The original circuit is also shown below. It was found through a DC analysis that $I_{C1}=50\mu$ and $I_{C2}=25\mu$.

(a) Find the ac parameters

- a. $r_{\pi 1}$ (3 points) = $\frac{\beta}{g_{m1}} = \frac{20}{2m} = 10k$
- b. $r_{\pi 2}$ (3 points) = $\beta/g_{m2} = 20/1m = 20k$
- c. g_{m1} (3 points) = $I_{C1}/V_T = 50\mu/25m = 2m$
- d. g_{m2} (3 points) = $I_{C2}/V_T = 25\mu/25m = 1m$

(b) Find that input resistance, R_{in} . (Ignore the AC input source V_s , include the 100 ohm) (12 points)

(c) Find the output resistance, R_o . (Ignore the load resistor of 1k to the right of arrow) (6 points)

(d) Find the overall gain, V_o/V_s . (25 points)

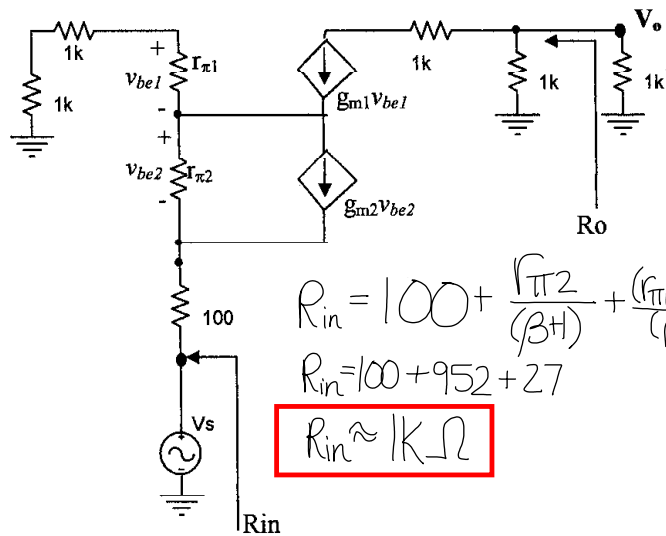
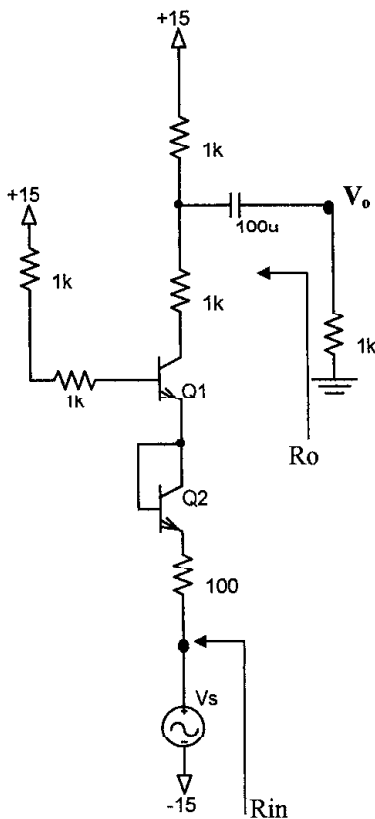

$$R_{in} = 100 + \frac{r_{\pi 2}}{\beta + 1} + \frac{(r_{\pi 1} + 2k)}{(\beta + 1)^2}$$

$$R_{in} = 100 + 952 + 27$$

$$R_{in} \approx 1k\Omega$$

$R_o = 1k \Rightarrow g_{m1}v_{be1}$ becomes open so that the 1k tied to it is floating.

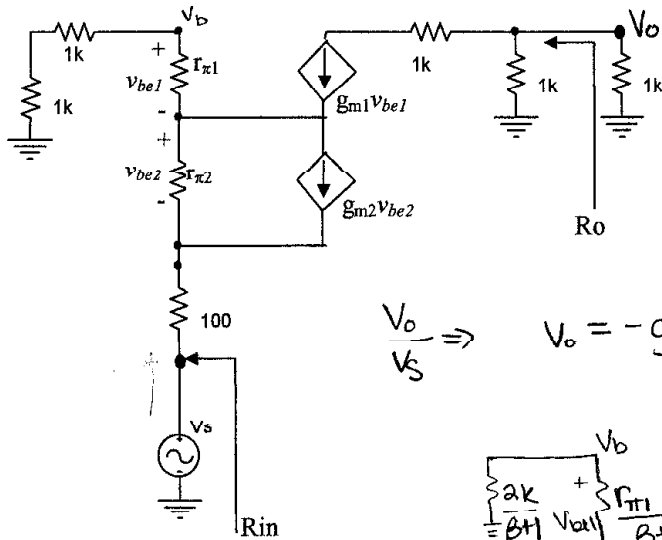

$r_{\pi 1} = 10k$
 $r_{\pi 2} = 20k$
 $g_{m1} = 2m$
 $g_{m2} = 1m$

$\frac{V_o}{V_s} \Rightarrow V_o = -g_{m1} V_{be1} (1k \parallel 1k)$

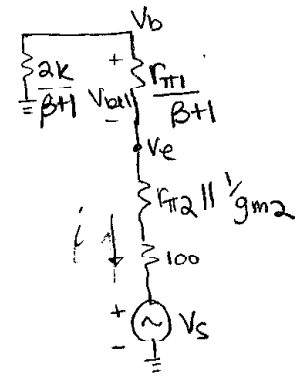

$i = \frac{-V_s}{R_{in}} = 616 \mu \cdot V_s$
 $V_{be} = +i \frac{r_{\pi 1}}{\beta + 1} = -0.29 V_s$

$V_{be} = \frac{-r_{\pi 1}}{\beta + 1} \cdot \frac{V_s}{R_{in}}$

$V_o = -g_{m1} \left(-\frac{r_{\pi 1}}{\beta + 1} \right) \frac{V_s}{R_{in}} (500)$

$\frac{V_o}{V_s} = -2m \left(-\frac{10k}{21} \right) \frac{500}{1623} = +0.3 \text{ V/V}$

Using voltage divider:

$V_e = \frac{\left(\frac{r_{\pi 1}}{\beta + 1} + \frac{2k}{\beta + 1} \right) V_s}{\left(\frac{r_{\pi 1} + 2k}{\beta + 1} \right) + r_{\pi 2} \parallel \frac{1}{g_{m2}} + 100} = 0.35 V_s$

$V_b = \frac{\frac{2k}{\beta + 1} - V_e}{\frac{r_{\pi 1}}{\beta + 1} + \frac{2k}{\beta + 1}} = 0.166 V_e = 0.058 V_s$
 $V_{be} = V_b - V_e = -0.29 V_s$

Points)

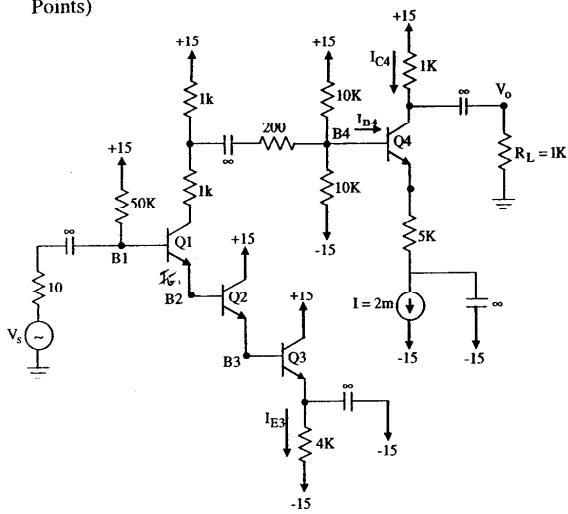

- a) α I_{E3}
 b) I_{C4}
 c) I_{B4}
 d) V_{C4}
 e) V_{B2}

$$I_{C4} = \alpha I_{E1}$$

$$I_{C4} = \left(\frac{100}{101}\right) 2m$$

$$I_{C4} = 1.98 mA$$

$$I_{B4} = (1 - \alpha) I_E$$

$$I_{B4} = \left(1 - \frac{100}{101}\right) (2m)$$

$$I_{B4} = 19.8 \mu A$$

$$V_{C4} = 15 - I_{C4}(1000)$$

$$= 15 - (1.98m)1000$$

$$V_{C4} = 13.02 V$$

$$15 - I_{B1}(50k) - 0.7 - 0.7 - 0.7 - I_E(4k) + 15 = 0$$

$$I_{B1} = (1 - \alpha) I_{E1}$$

$$I_{E1} = I_{B2}$$

$$I_{E1} = (1 - \alpha) I_{E2}$$

$$I_{E2} = I_{B3}$$

$$I_{E2} = (1 - \alpha) I_{E3}$$

$$I_{B1} = (1 - \alpha)(1 - \alpha)(1 - \alpha) I_{E3} =$$

$$\alpha = \frac{\beta}{\beta + 1} = \frac{100}{101}$$

$$\left(1 - \frac{100}{101}\right)^3 I_{E3} = I_{B1}$$

$$15 - \left(1 - \frac{100}{101}\right)^3 I_{E3}(50k) - 2.1 - I_E(4k) + 15 = 0$$

$$I_{E3} \left(-\left(1 - \frac{100}{101}\right)^3 (50k) - 4k\right) = -15 + 2.1 - 15$$

$$I_{E3} (-4k) = -27.9$$

$$I_{E3} = 6.975 mA$$

$$V_{B2} = 15 - I_{B1}(50k) - 0.7$$

$$= 15 - (1 - \alpha)(1 - \alpha)(1 - \alpha) I_{E3}(50k) - 0.7$$

$$= 15 - \left(1 - \frac{100}{101}\right)^3 (6.975m) 50k - 0.7$$

$$V_{B2} = 14.2997 V$$

a.) a) $I_{E3} = 6.975 mA$ ✓

b) $I_{C4} = 1.98 mA$ ✓

c) $I_{B4} = 19.8 \mu A$ ✓

d) $V_{C4} = 13.02 V$ ✓

e) $V_{B2} = 14.2997 V$ ✓

Points)

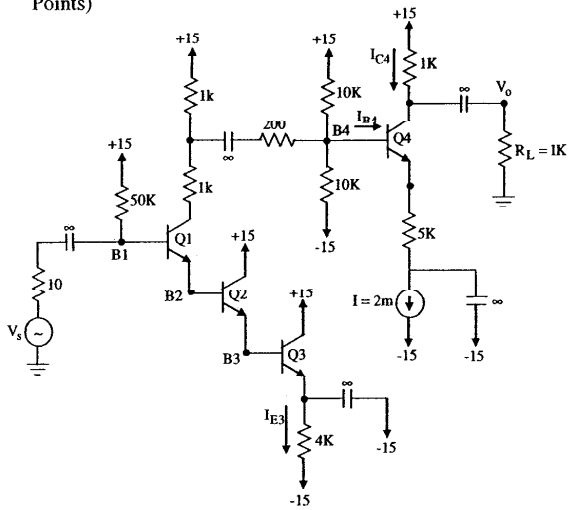

- I_{E3}
- I_{C4}
- V_{B4}
- V_{C4}
- V_{B2}

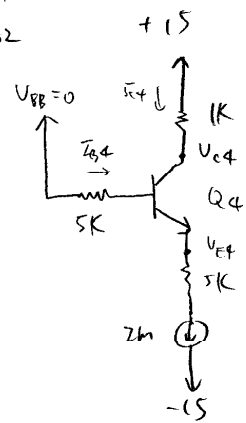

a) $15 = 50k \frac{I_{E1}}{\beta+1} + 2.1 + 4k \cdot I_{E3} - 15$

$I_{E1} = I_{B2}$, $I_{E2} = I_{B2}(\beta+1) - I_{B3}$, $I_{E3} = I_{B3}(\beta+1)$

$I_{B2}(\beta+1) = \frac{I_{E3}}{\beta+1}$ $I_{B3} = \frac{I_{E3}}{\beta+1}$

$I_{E1} = I_{B2} = \frac{I_{E3}}{(\beta+1)^2}$ $I_{E1} = 6.99 \mu A$

$21.9 = 50k \cdot \frac{I_{E3}}{(101)^2} + 4k I_{E3}$

$= I_{E3} \left(\frac{50k}{(101)^2} + 4k \right)$

$I_{E3} = 6.99 \mu A$ ✓

$V_{E3} = -15 + 4k I_{E3}$
 $= 12.88$

$V_{B3} = 12.88 + 0.17$
 $= 13.58 V$

$V_{B2} = 12.88 + 1.4$ ✓
 $= 14.28 V$

$V_{E2} = 13.58 V$
 $V_{E1} = 14.28 V$

$V_{B1} = 14.98 V$

$I_{C1} = 0.99 I_{E1}$
 $= 6.96 \mu A$

$V_{C1} = 15 - I_{C1} \cdot 2k$
 $= 14.99 V$

∴ $V_{C1} \geq V_{B1} > V_{E1}$ $V_{C2} \geq V_{B2} > V_{E2}$
 Q_1 act. Q_2 act.
 $V_{C3} \geq V_{B3} > V_{E2}$
 Q_3 act

$V_{BB} = \frac{30}{2} - 15$ $V_{E4} = -15 + 10$
 $= 0$ $= 5V$

$I_{B4} = \frac{2m}{101}$ $V_{B4} = -4.3 V$
 $= 19.8 \mu A$ ✓

$V_{B4} = 5k \cdot I_{B4}$
 $= 99 mV$

$I_{C4} = 2m - 19.8 \mu A$
 $= 1.9802 \mu A$ ✓

$V_{C4} = 15 - I_{C4} \cdot 1k$ ✓
 $= 13.0198 V$

∴ $V_{C4} \geq V_{B4} > V_{E4}$
 Q_4 act

∴ Assume is act is correct.

Points)

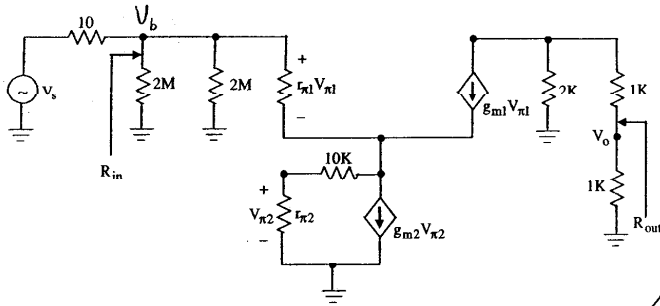

$$I_{E1} = 2.525 \text{ mA}$$

$$I_{E2} = 1.2625 \text{ mA}$$

$$r_{\pi 1}$$

$$r_{\pi 2}$$

$$g_{m 1}$$

$$g_{m 2}$$

$$a) \quad I_{B1} = \frac{I_{E1}}{\beta + 1} = 25 \mu\text{A} \quad r_{\pi 1} = \frac{25 \mu\text{A}}{I_{B1}} = 1 \text{ k}\Omega \quad g_{m1} = \frac{\beta}{r_{\pi 1}} = 100 \frac{\text{A}}{\text{V}}$$

$$I_{B2} = \frac{I_{E2}}{\beta + 1} = 12.5 \mu\text{A} \quad r_{\pi 2} = \frac{25 \mu\text{A}}{I_{B2}} = 2 \text{ k}\Omega \quad g_{m2} = \frac{\beta}{r_{\pi 2}} = 50 \frac{\text{A}}{\text{V}}$$

$$b) \quad R_{in} = 2 \text{ M}\Omega \parallel 2 \text{ M}\Omega \parallel \left[r_{\pi 1} + 101 \cdot (10 \text{ k}\Omega + r_{\pi 2}) \right]$$

$$= 1 \text{ M}\Omega \parallel 1.213 \text{ M}\Omega$$

$$= 548 \text{ k}\Omega$$

$$c) \quad R_{out} = 1 \text{ k}\Omega + 2 \text{ k}\Omega = 3 \text{ k}\Omega$$

$$d) \quad V_o = \frac{-g_{m1} V_{\pi 1}}{2} \cdot 1 \text{ k}\Omega$$

$$V_b = V_s \cdot \frac{R_{in}}{10 \text{ k}\Omega + R_{in}}$$

$$\approx V_s$$

$$V_{\pi 1} = V_b \cdot \frac{r_{\pi 1}}{r_{\pi 1} + (10 \text{ k}\Omega + r_{\pi 2}) \cdot 101} = V_s \cdot 829.4 \mu\text{A}$$

$$\frac{V_o}{V_s} = \frac{-g_{m1} \cdot 829.4 \mu\text{A} \cdot 1 \text{ k}\Omega}{2}$$

$$= -41.2 \text{ mV/V}$$

Points)

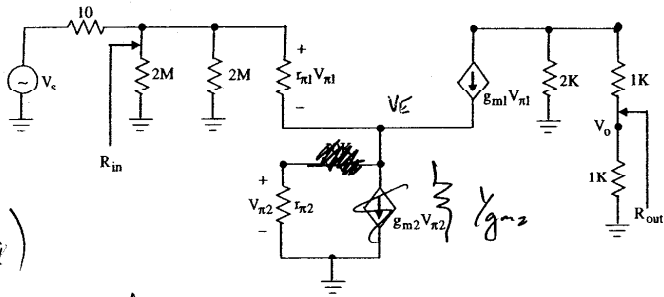

- a) $r_{\pi 1}$
- b) $r_{\pi 2}$
- c) $g_{m 1}$
- d) $g_{m 2}$

$$\frac{1k}{1k+1k}$$

a)

$$a.) r_{\pi 1} = \frac{V_T}{I_{B1}} ; I_{E1} = 2.525 \text{ mA}$$

$$r_{\pi 1} = 1000 \Omega$$

$$I_{B1} = (1-\alpha)(2.525 \text{ mA})$$

$$\left(1 - \frac{100}{101}\right) (2.525 \text{ mA}) = 25 \mu\text{A}$$

$$V_o = V_s \left(\frac{1k}{1k+1k} \right) \approx V_s$$

$$V_E = V_C = V_s \left(\frac{(g_{m2} // r_{\pi 2})(\beta+1)}{(g_{m2} // r_{\pi 2})(\beta+1) + r_{\pi 1}} \right)$$

$$= \frac{1004.975}{1004.975 + 1000} =$$

$$V_E \approx \frac{1}{2} V_s$$

$$b.) r_{\pi 2} = \frac{V_T}{I_{B2}} ; I_{E2} = 1.2625 \text{ mA}$$

$$r_{\pi 2} = 2000 \Omega$$

$$I_{B2} = \frac{(1-\alpha)(1.2625 \text{ mA})}{1} = 12.5 \mu\text{A}$$

$$c.) g_{m1} = I_{C1} / V_T$$

$$g_{m1} = 100 \text{ mA/V}$$

$$I_{C1} = \alpha I_{E1} = \left(\frac{100}{101}\right) (2.525 \text{ mA}) = 2.5 \text{ mA}$$

$$V_o = -(100 \text{ mA/V}) (V_s - \frac{1}{2} V_s) // 1k$$

$$V_o = -100 \text{ mA/V} (1 - \frac{1}{2}) // 1k$$

$$d.) g_{m2} = I_{C2} / V_T$$

$$g_{m2} = 50 \text{ mA/V}$$

$$I_{C2} = \alpha I_{E2} = 1.25 \text{ mA}$$

$$\frac{V_o}{V_s} = -0.1 \left(\frac{1}{2}\right) // 1k$$

$$\frac{V_o}{V_s} = -50 \text{ V/V}$$

b.)

$$I = g_{m2} V_{be2} \quad V = V_{be2}$$

$$R_{eq} = \frac{V_{be2}}{g_{m2} V_{be2}} = \frac{1}{g_{m2}}$$

$$R_{in} = 1M // \left(r_{\pi 1} + (\beta+1) \left(r_{\pi 2} // \frac{1}{g_{m2}} \right) \right) = 1M // \left(1000 + (101) \left(2000 // \frac{1}{50 \text{ mA/V}} \right) \right)$$

$$= 2,991 \Omega$$

$$R_{in} = 2,991 \Omega$$

$$c.) R_{out} = 2k52 \times$$

3

Problem 3 – (5 points)

Use $|V_{BE}|=0.7$, $\beta=100$, $V_T=25\text{mV}$ (V_s is an ac source), ignore r_o .

Will this circuit work as an amplifier? Why or why not?

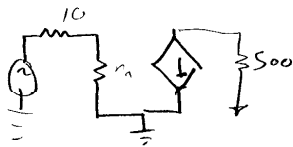
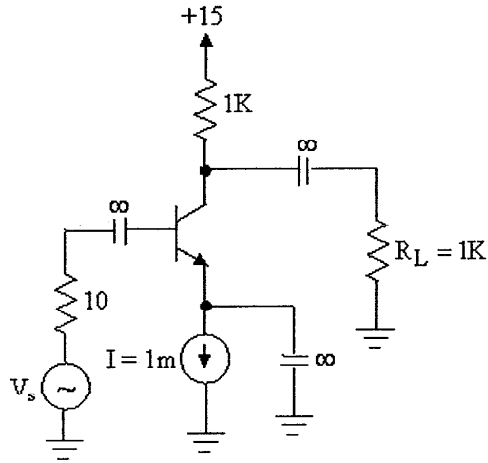

NO, IT WILL NOT

THE BASE IS DISCONNECTED
WHEN ANALYZING THE DC
PARAMETERS. THUS WE CAN'T
BIAS OUR CIRCUIT BECAUSE OF
THIS FLOATING NODE.