

ECE 2280

REVIEW FOR EXAM 1

The material below we have covered so far this semester is summarized (but NOT limited to) the following:

1. Understand the difference between DC & AC signals.
2. Understand how to analyze a circuit (with or without caps in it) to obtain transfer function.
3. Understand how to plot the Bode plots from an equation or circuit. Understand how to read a Bode plot (interpret frequency range for bandwidth, specify exact value, etc)
4. Amplifiers:
 - a. Understand how to apply the Voltage Amplifier model to multistage single input amplifiers. Be able to analyze to obtain the transfer function. Understand results.
 - b. Compensation of real op-amp imperfections (Slew rate, clipping, input bias currents, voltage offset, frequency limitations, finite gain, etc.)
5. Diodes:
 - a. Analyze diode circuit using ideal model
 - b. Analyze diode circuit using constant voltage drop model.

1. Sketch the Bode (both magnitude & phase) plot for: {label as many y values as possible for both magnitude and phase and/or each slope along with showing all your work}

$$H(s) = \frac{-2 \times 10^6 (s+10)^2}{s \cdot (s+1k)(s+10k)}$$

a) What is the estimated or actual magnitude value at $\omega=10k$ rad/sec (in dB):

b) What range of frequency will this circuit operate correctly:

$$H(s) = \frac{-2 \times 10^6 (s + 10)^2}{s \cdot (s + 1k)(s + 10k)}$$

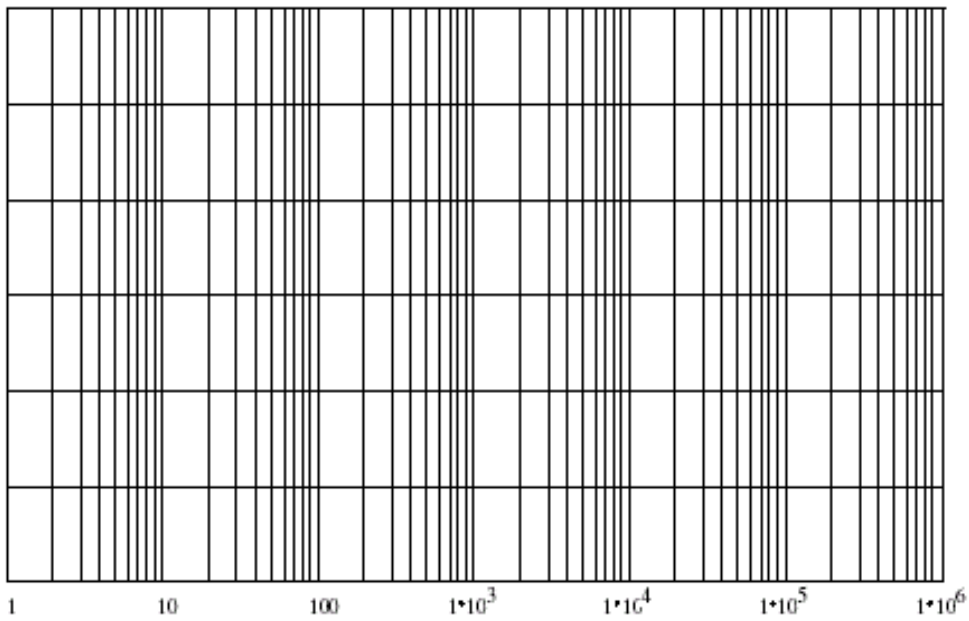
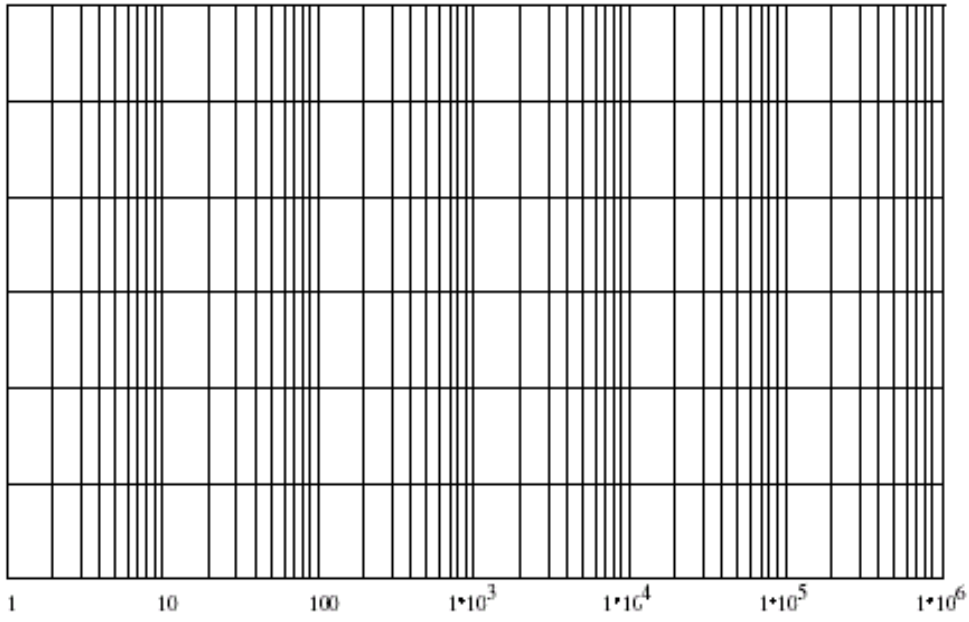

2. V_s is an AC signal. Assume linear operation for both amplifiers with only the following nonideal effects:

$$A_{vo}=10, \quad R_{in}=20k\Omega, \quad R_o=2k\Omega \quad \text{power supplies} = \pm 12 \text{ V}$$

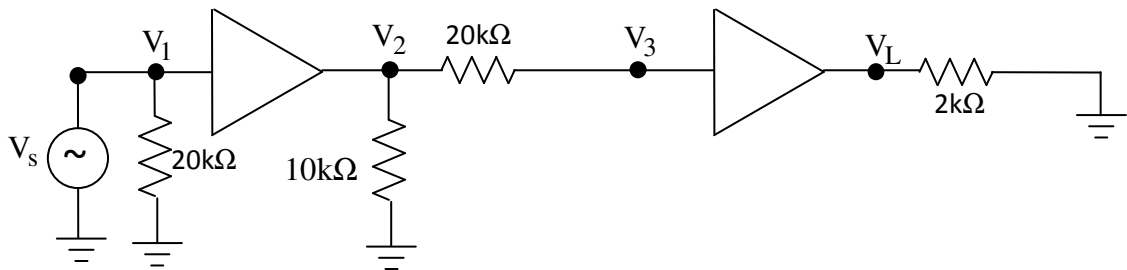

- Draw this 2 stage amplifier using the voltage amplifier model. Make sure to label V_s , V_1 , V_2 , V_3 , and V_L on the schematic.
- Find the voltage gain V_L/V_s .
- What is the maximum amplitude for V_s considering the limits of a nonideal amplifier? (*Hint: Consider first the maximum output voltage possible*)

3.

Assume all diodes are identical and have $V_{D0}=0.7V$, $n=5$, and $V_T=25mV$. Use the **constant voltage drop** method. Verify that your assumption for the diode operation (i.e. on or off) are correct. Find the following making sure you find the correct operation of the diodes.

- State your assumptions (diode is on/off).
- The current I_{D1}
- The current I_{D2}
- The current I_{D3}
- The voltage V_o
- Verification to prove your assumptions for the diodes are correct.

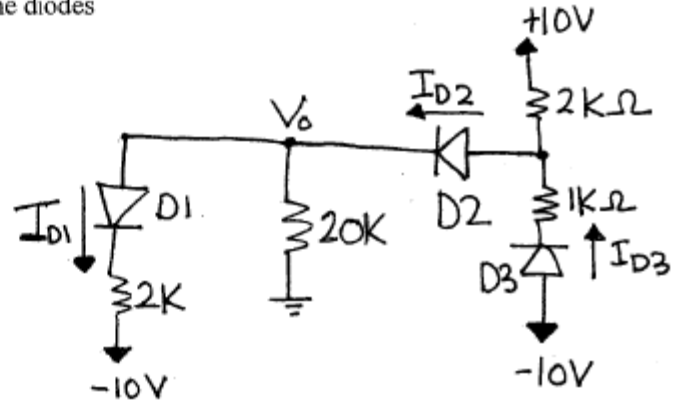

4.

You are given the following characteristics for a real amplifier:

Input offset voltage, $V_{ios}=3\text{mV}$
Input Resistance, $R_i=2\text{M}\Omega$
Unity-gain bandwidth, $f_T=20\text{MHz}$
Output swing limits, within 2Volts of power supply
Slew Rate, $\text{SR}=6\frac{\text{V}}{\mu\text{sec}}$

The following circuit is powered at $\pm 15\text{V}$:

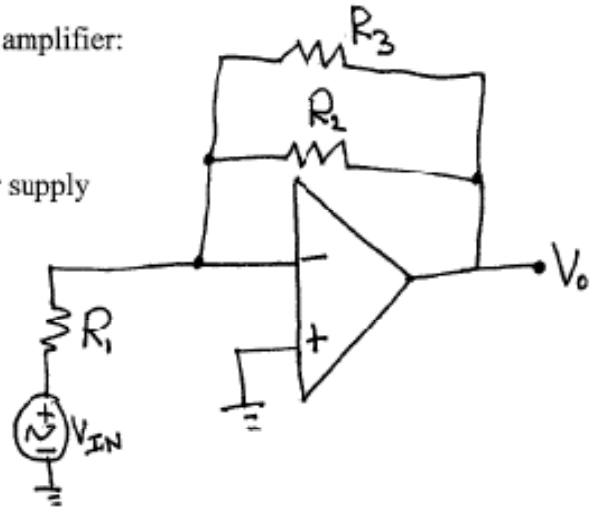

- If $R_1=20\text{k}$ and $R_2=R_3=100\text{k}$, what is the bandwidth of the circuit. Consider both the effect due to slew rate (use the maximum output value possible) compared to the effect due to the unity gain bandwidth.
- For $V_{in}=0.002\sin(2\pi 90kt)$, what is the PEAK(not peak to peak) value at the output considering the input offset voltage?
- How should the circuit above be modified to minimize the effect of the input bias current? Draw the schematic of the modified circuit and state values of added component(s).