

Notes for Power Supply Project:

The schematic below shows how to use the components discussed in class to create a power supply for dual rails (positive DC value and negative DC value).

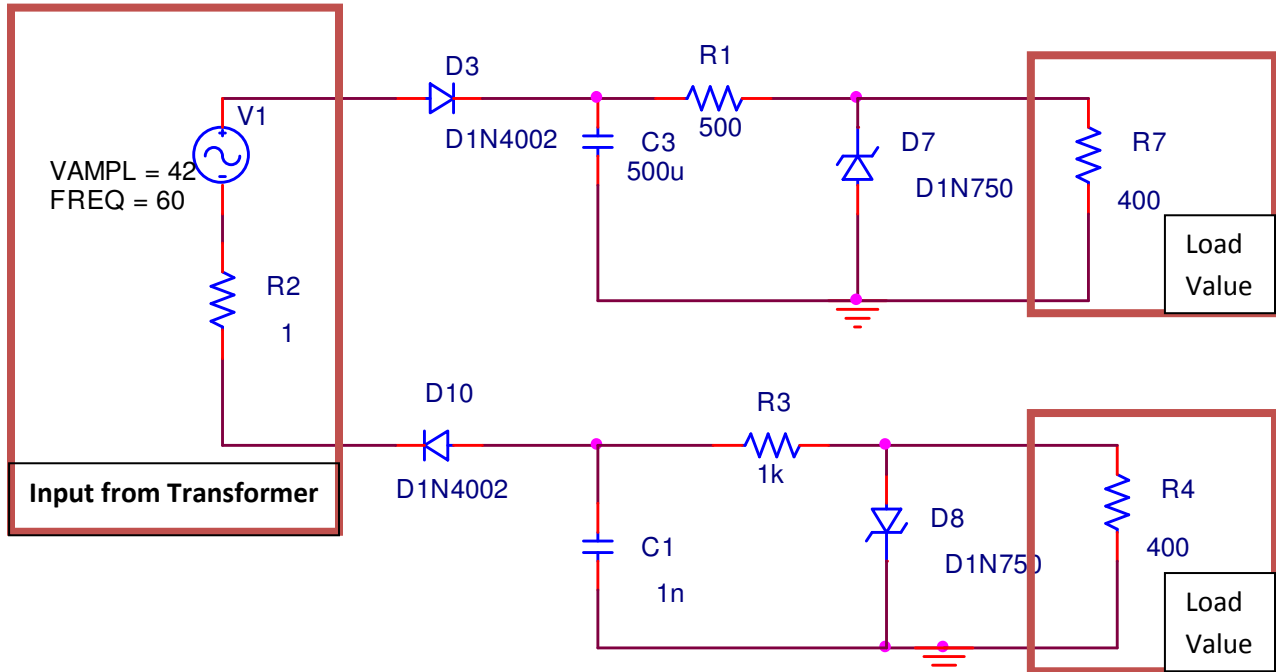

Note that the above design does not simulate correctly with the values given above. It provides only a starting point for your design. The above voltage supply, V1, models your transformer and therefore will have the amplitude value that you measure from the particular transformer you use from the stockroom or if you purchase your own. Depending on how you utilize the transformer, you may also want to split the input into two input voltage sources.

The load value on each of the rails also needs to be calculated and can be found from the following equation:

$$R_L = \frac{V_{supply\ value}}{I_{measured\ in\ lab}}$$

This load value models the current drawn from each of your power supplies when the max current is measured.