

# Antennas for Non-Specialists

Keigo Iizuka

Department of Electrical and Computer Engineering, University of Toronto  
10 King's College Road, Toronto, Canada M5S 1A4  
E-mail: keigo.iizuka@utoronto.ca

---

## Abstract

This article reports the experience of giving a hands-on antenna course to a group of participants who were not antenna specialists. The discussion of the results is presented in the format of a student-instructor dialog. The questions asked by the participants were sometimes very challenging to answer, especially without resorting to mathematical formulas. For the benefit of those antenna instructors who are interested in imitating this course, a set of instructions for performing the experiments is presented at the beginning of each experiment; these can be used as worksheets to hand out to the participants.

**Keywords:** Antennas; antenna theory; antenna arrays; antenna radiation patterns; antenna measurements; reflection; mobile antennas; engineering education; radomes; impedance matching; baluns; current measurement; coaxial transmission lines

Recently, many consumer products have started using wireless connections: cellular phones, keyless entries to automobiles, and remote controls for household items. Replenishing vending machines, which sell a wide range of commodities from soft drinks to concert tickets, has become easier through wireless connections that monitor the machines' inventory. Each of these examples requires connections that need a pair of antennas.

Omron Corporation, a manufacturer of automation components, approached me and asked me to present a practical course on "Antennas for Non-Specialists" to newly recruited technical staff who had not yet been exposed to antenna theory. I was given the further challenge of presenting this course without using any mathematical formulas. For the benefit of antenna specialists who may encounter a similar situation, or who want to build a new antenna instruction laboratory, I would like to report my experience with this challenge.

The course consisted of the following sessions:

1. (Experiment) Measurements of the radiation pattern of a dipole antenna.
2. (Experiment) Distribution of current, charge, and Poynting vector on a dipole antenna.
3. (Discussion) Why do antennas radiate radio waves?
4. (Experiment) Reflection of the radio wave.
5. (Experiment) Steering an antenna array pattern.

Although prior knowledge of antenna theory is not required to perform these experiments, students should possess a basic knowledge of elementary physics.

This article is divided into five major sections, corresponding to the five sessions in the course. The introductory section of each

experiment contains a description of the experimental setup and the tasks the student is expected to perform. Antenna instructors who are interested in imitating this course may find it convenient to use these introductory sections as handouts for their students, as a guide to performing the experiments. Following each introductory section, the experimental results are subdivided into topics and discussed. The discussion of the results is presented in the format of a student-instructor dialog. Some of the questions that the students ask most frequently are not necessarily easy to answer.

## 1. Measurement of the Radiation Pattern of a Dipole Antenna

### Experimental Instructions

As a preliminary exercise, measure the impedance of 50 ohm coaxial cables using any method of your choosing. How well do the measurements agree with the 50 ohm specification?

After completing the preliminary exercise, measure the radiation pattern of a half-wave dipole antenna by following these steps:

1. As shown in Figure 1, connect the equipment using the coaxial cables.
2. Rotate the probe (receiving) antenna at a constant radius around the transmitting antenna. Make the radius as large as space permits. While rotating the probe antenna, keep the probe's axis tangent to the constant radius, as shown in Figure 1. This orientation is used to measure  $E_{\theta}(r)$ , which is the field component tangential to the arc of radius  $r$ . Repeat measurements of  $E_{\theta}(r)$  for various radii, and verify that the radiation pattern is doughnut-shaped, as shown in Figure 2.

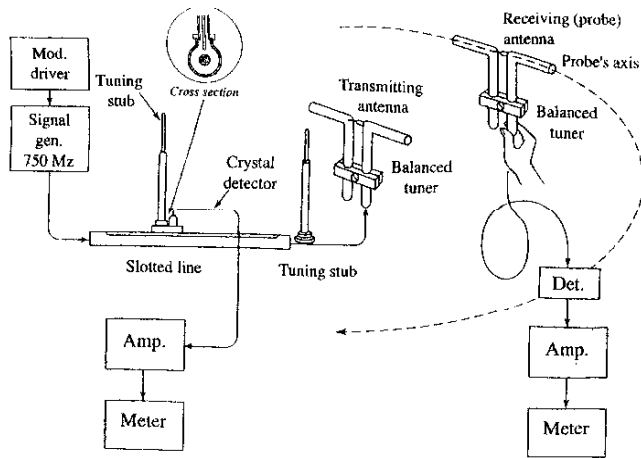

Figure 1. The arrangement for measuring antenna radiation patterns.

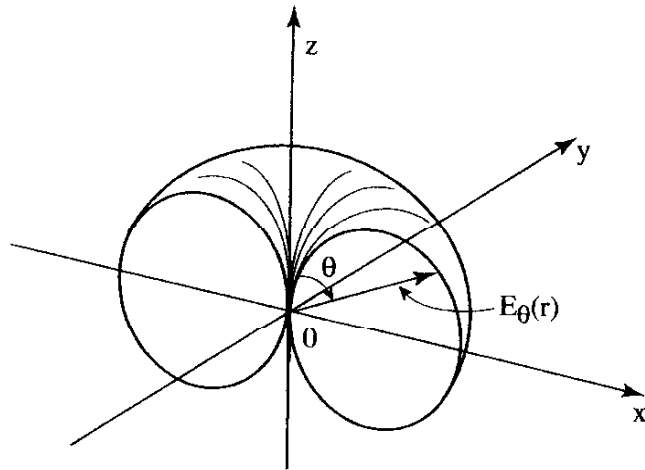

Figure 2. A cutout view of the doughnut-shaped radiation pattern corresponding to  $E_{\theta}(r)$ . The length of the line from the origin to the surface represents the amplitude of  $E_{\theta}(r)$ .

3. As shown in Figure 3, orient the axis of the probe antenna so that it is collinear with the transmitting antenna. This orientation is used to measure  $E_z(z)$ , which is the field component in the axial direction. How does  $E_z(z)$  change as you increase or decrease the distance  $z$  in the vicinity of the transmitting antenna? How does the strength of  $E_z(z)$  compare with  $E_{\theta}(r)$ ? Which component,  $E_{\theta}(r)$  or  $E_z(z)$ , would be more advantageous for very-short-distance communication, such as the case of a keyless entry to an automobile?

[End of instructions.]

## 1.1 Impedance of Coaxial Cables

### Discussion of the Experimental Results

**Instructor:** We will now discuss the results of the preliminary exercise, which was to measure the impedance of the 50 ohm coaxial cables that are used to connect the equipment.

**Student:** When I measure the impedance of the coaxial cable, my multimeter reads infinite ohms. I was expecting a reading of 50 ohms. Is there something wrong with my measurement?

**Instructor:** You have made a common mistake, which is to attempt to measure the impedance with a multimeter designed for dc measurements. This will result in an impedance measurement of infinite ohms. Instead of a multimeter, you should use a voltmeter designed for high frequencies, such as an impedance bridge or a vector voltmeter.

**Student:** I don't quite understand the implications of the high frequencies. Can you elaborate?

**Instructor:** The coaxial cable consists of inner and outer conductors. The two conductors in the coaxial cable are spaced by an annular gap that forms a capacitor. Even though the capacitance,  $C$  farads per unit length, is small, as the frequency is increased, the susceptance,  $j\omega C$ , becomes a quantity that cannot be ignored.

Another quantity of concern is the inductance. As an alternating current flows through the conductor, a time-varying magnetic flux is created. The time-varying magnetic flux induces a counter electromagnetic force that resists the original current flow in the conductor. The amount of counter-electromagnetic force is quantified as the inductance,  $L$  henries per unit of length, of the coaxial cable. Even though the amount  $L$  is small, as the frequency is increased, the reactance,  $j\omega L$ , becomes a quantity that can no longer be ignored.

As the length of the coaxial cable is increased, the coaxial cable can be short circuited by the capacitance, but the series inductance helps the coaxial cable to be open-circuited. These two mutually counteracting effects balance as the length of the cable (in terms of the wavelength) is increased, and this finally reaches the characteristic impedance,  $Z_c = \sqrt{L/C}$ . The characteristic impedance of the most common coaxial cable is  $Z_c = 50$  ohms.

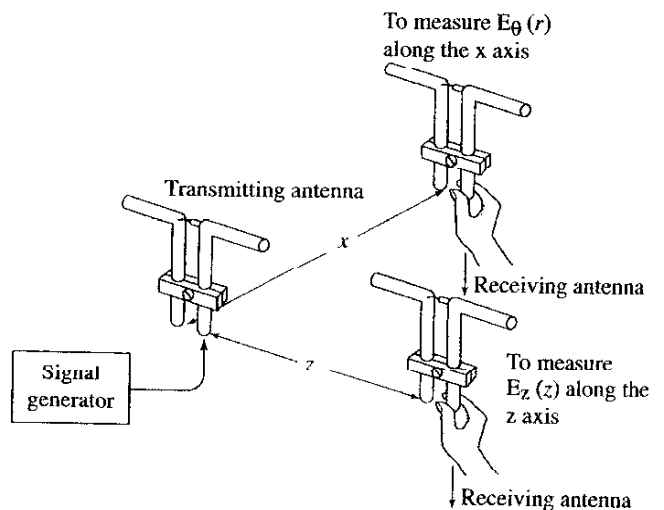

Figure 3. A close-up of the relative positions of the transmitting and receiving (probe) antennas for measuring  $E_{\theta}(r)$  and  $E_z(z)$ .  $E_{\theta}(r)$  is the field component tangential to radius  $r$ .  $E_z(z)$  is the field component in the axial direction of the transmitting antenna.

The characteristic impedance can be obtained by measuring the current,  $i(\omega)$ , into an *infinitely long* coaxial cable when a voltage,  $v(\omega)$ , at a high frequency is applied. Taking the quotient gives

$$Z_c = \frac{v(\omega)}{i(\omega)} = 50 \text{ ohms.}$$

**Student:** An “infinitely long” cable is an idealization. In practice, how long should the cable be to make an accurate measurement of the characteristic impedance?

**Instructor:** A long cable, of the order of hundreds of wavelengths, would be needed to make an accurate measurement of the characteristic impedance. This leads to another common mistake that students make: attempting to measure the impedance of a coaxial cable that is too short.

A better way to measure the impedance of the coaxial cable is to use the slotted line, shown in Figure 1, and a set of calibrated load impedances. This method is based on the fact that the reflection is diminished when the load impedance becomes the same as that of the coaxial cable (this is precisely the principle that is used to match the antenna to the coaxial cable). The slotted line (see the insert in Figure 1) is used to monitor the standing-wave pattern on the line that is caused by the existence of the reflection on the coaxial cable. A voltage standing wave ratio ( $V_{max}/V_{min}$ ) of unity means no reflection.

In other words, you should measure the voltage standing wave ratios with different loads. As the impedance of the load approaches that of the coaxial cable, the voltage standing wave ratio approaches unity. The load impedance that gives a voltage standing wave ratio of unity is the characteristic impedance of the coaxial cable.

**Student:** Why is the impedance of the coaxial cables important in the design of a transmitting antenna system?

**Instructor:** In order to send the maximum microwave power out of the antenna into air from the microwave signal generator, the impedance of the antenna has to be designed to be as close as possible to that of the coaxial cable. If the antenna impedance is not the same as that of the coaxial cable, the signal is reflected at the antenna driving point and goes back into the signal generator instead of flowing into the antenna wire, and the amount of radiation is reduced.

Besides a decrease in the transmitted power from the antenna, the voltage maxima of the standing wave can cause arcing inside the coaxial cable, when the transmitter power is pushed to the limit. Prevention of arcing inside the coaxial cable connecting a high-power transmitter on the ground to the antenna on the top of a tower needs serious consideration.

**Student:** Is it always necessary to use 50 ohm coaxial cables?

**Instructor:** The important point to remember is that the antenna impedance should match the impedance of the coaxial cable, and for this reason, cables with a characteristic impedance close to that of the antenna’s impedance are selected. If the antenna impedance is other than 50 ohms, an impedance transformer or mismatch compensators, such as tuning stubs, are used to change the antenna’s impedance to 50 ohms.

## 1.2 Near-Field Radiation Pattern of a Half-Wave Dipole Antenna

### Discussion of the Experimental Results

**Instructor:** By selecting large radii and rotating the receiving (probe) antenna around the transmitting antenna, as shown in Figure 1, you should be able to verify the doughnut-shaped radiation pattern illustrated in Figure 2. It is important to maintain the correct orientation of the probe antenna in order to observe this pattern, which is the pattern that corresponds to  $E_\theta(r)$ . The correct orientation of the probe is tangent to the arc of constant radius, as shown in Figure 1. It is also important to select large radii for the measurements.

**Student:** At first, I was having difficulty observing the pattern because I wasn’t paying careful attention to the orientation of the probe. When I took care to orient the probe properly, I was able to observe the doughnut-shaped pattern.

**Instructor:** The doughnut-shaped radiation pattern is observed when the distance between the transmitting and probe antennas is large. When the distance is very close, the behavior is quite different. In general, the case of keyless entry to a car belongs to the latter geometry. For instance, in Figure 2, the field  $E_\theta(r)$  is zero along the  $z$  axis.

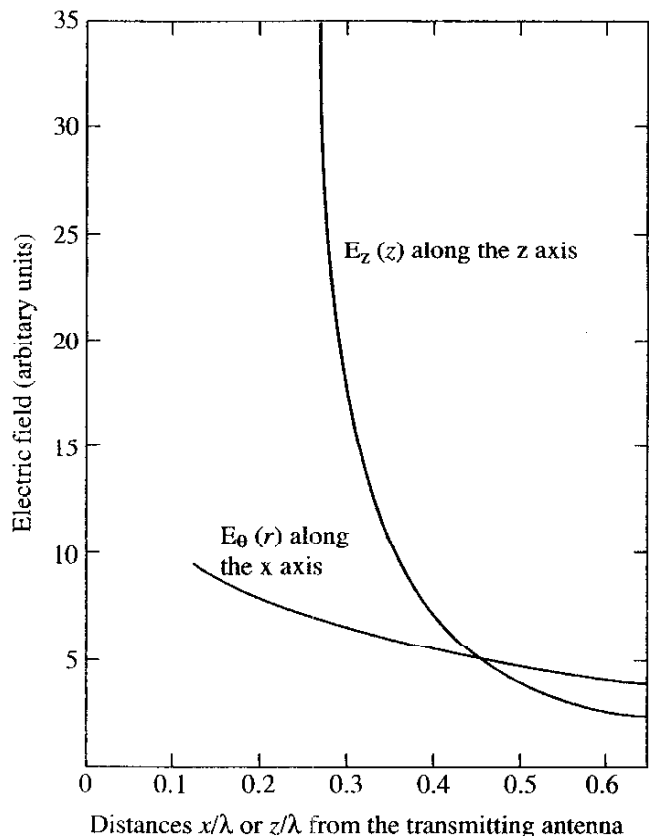

Figure 4.  $E_\theta(r)$  and  $E_z(z)$  as a function of the distance  $x$  or  $z$  in the vicinity of the antenna.

**Student:** Does this really mean that there is no field at all along the  $z$  axis?

**Instructor:** Let us examine the field in the vicinity of the antenna more closely, as shown in Figure 3. What did you observe with the probe antenna oriented to measure  $E_z(z)$  instead of  $E_\theta(r)$  in the near field?

**Student:** The reception was strong when I held the probe antenna close to the transmitting antenna.

**Instructor:** The reception is strong when the distance between the probe and transmitting antennas is short, but did you also notice that as soon as the distance between the probe and transmitting antenna exceeded one half wavelength, the reception became much weaker? Figure 4 compares the reception of  $E_z(z)$  and  $E_\theta(r)$  with respect to the distance  $r$  or  $z$  from the transmitting half-wave dipole antenna. The field strength  $E_\theta(r)$  decreases with distance by  $1/r$ , while that of  $E_z(z)$  decreases much faster, as  $1/z^3$ .  $E_\theta(r)$  is called the radiation field, while  $E_z(z)$  is the nonradiating field. Figure 2 presents  $E_\theta(r)$  in the far region. Which field is more advantageous for communication?

**Student:** It depends on the distance between the transmitting and receiving antennas.

**Instructor:** That is correct. For distances shorter than  $\lambda/2$ , it is more advantageous to use  $E_z(z)$ , but for distances longer than  $\lambda/2$ , it is better to use  $E_\theta(r)$ . For instance, for a 1 MHz signal, distances shorter than 150 m will benefit more from  $E_z(z)$ , as in the case of keyless entry to a car, while distances longer than 150 m will get better reception with  $E_\theta(r)$ .

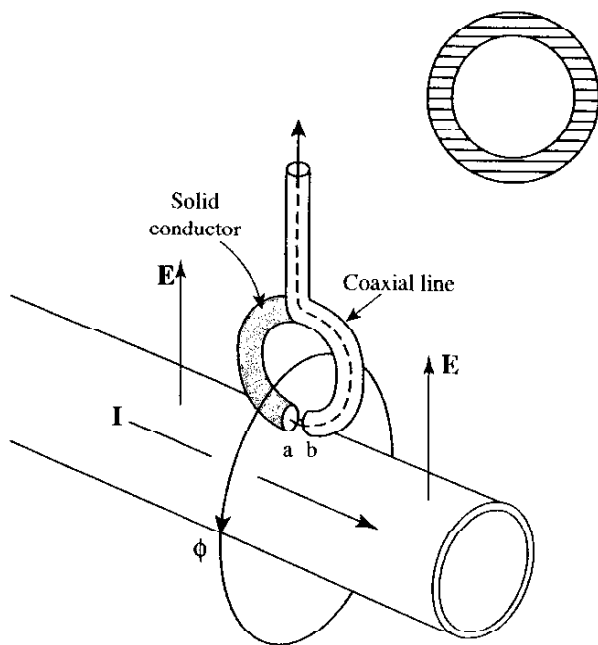

**Figure 5a.** A small-loop current probe with a symmetric structure.

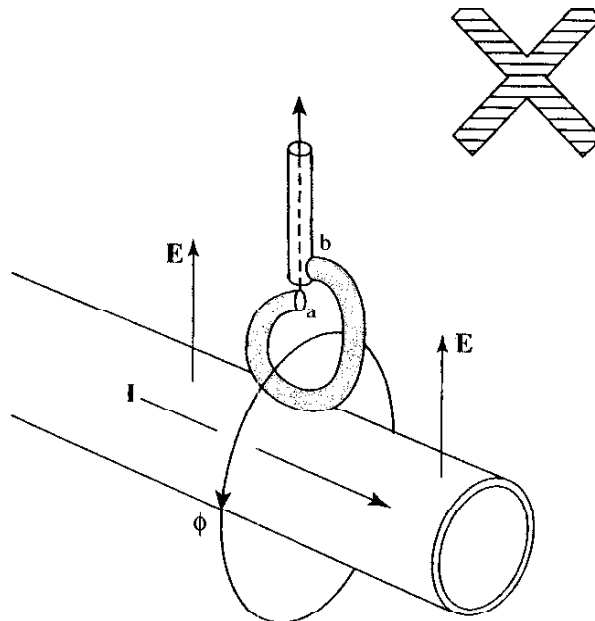

**Figure 5b.** A small-loop current probe with an asymmetric structure.

## 2. Measurement of Current, Charge, and the Poynting Vector

### Experimental Instructions

Measure the current, charge and Poynting vector as follows:

1. The antenna current sets up a time-varying magnetic flux,  $\phi$ , around the antenna. You can measure the antenna current by picking up this flux by means of a probe antenna in the shape of a small loop. Use the small loop antenna shown in Figure 5a to measure the current distribution on the half-wave dipole antenna. Why is it better to use a small-loop current probe with a symmetric structure (compare Figures 5a and 5b)?

2. Measure the charge distribution along the half-wave dipole using a small dipole antenna (see Figure 6.) The direction of the probe antenna should be parallel to the electric lines of flux from the charges. This means you should orient the probe perpendicular to the half-wave dipole axis, except at the ends of the dipole antenna. At both ends, orient the probe axis along any radial emanating from the end of the antenna. Why is the orientation of the charge probe in Figure 6a better than that in Figure 6b?

3. Measure the pattern of the Poynting vector,  $\mathbf{E} \times \mathbf{H}$ , coming out of the dipole. The Poynting vector gives an accurate picture of where the energy is emerging. To measure the Poynting vector, use the liquid-crystal film display shown in Figure 7. The cholesteric liquid crystal, which changes its color in response to heat, is painted over a thin Mylar resistive film of  $120\pi$  ohm square. It is the same principle as the microwave oven. The portion of the resistive film exposed to a higher intensity of the Poynting vector is heated more, and the liquid-crystal film changes its color to red in these portions. For this measurement, you may increase the output

power of the signal generator to about 1 W, but for safety reasons, finish the experiment rather quickly to avoid prolonged exposure.

[End of instructions.]

## 2.1 Current on the Dipole Antenna

### Discussion of the Experimental Results

**Instructor:** When you used the small loop probe antenna, shown in Figure 5a, to measure the current distribution on the transmitting antenna, what did you observe?

**Student:** The current distribution is indeed sinusoidal.

**Instructor:** Why is the symmetric probe shown in Figure 5a better than the asymmetric probe shown in Figure 5b for the current measurements?

**Student:** The probe is sensitive to both the magnetic flux and the  $\mathbf{E}$  field originating from the charge on the dipole antenna. The symmetric shape is better because it means that the  $\mathbf{E}$  field excitation is also symmetric with the probe, and does not contribute to the magnetic-flux measurement.

**Instructor:** That is correct. The small loop of the current-probe antenna is composed of a thin semi-circular, semi-rigid coaxial cable and a semi-circular solid conductor. The driving point is at a-b at the bottom of the loop, where b is the outer conductor of the semi-rigid coaxial cable and where the extension, a, of the inner conductor of the semi-rigid coaxial cable is connected to the solid conductor. The probe is actually exposed not only to the flux,  $\phi$ , but also to the  $\mathbf{E}$  field originating from the charge distribution on the dipole antenna. The symmetric shape with respect to the driving point a-b of the thin coaxial-cable feed line prevents excitation due to the  $\mathbf{E}$  field. If symmetric, the excitations on the left and right-hand sides of the loop antenna become identical, as indicated by the two arrows in Figure 5a. Because the excitation is the same on each side, there is no potential difference created between the gap a-b, and the  $\mathbf{E}$  field does

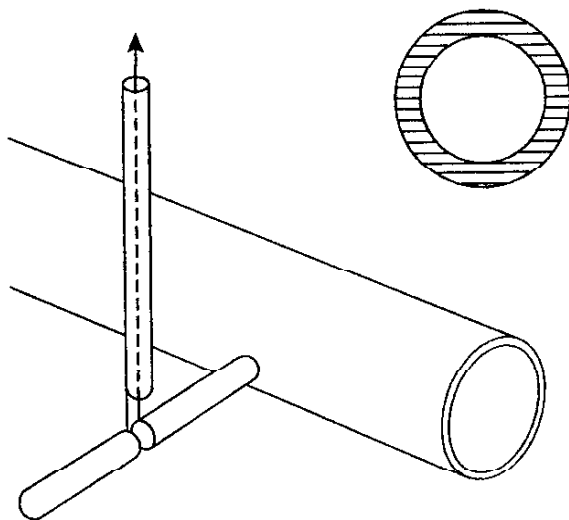

**Figure 6a.** The charge probe with the lead wire perpendicular to the radiating  $\mathbf{E}$  field.

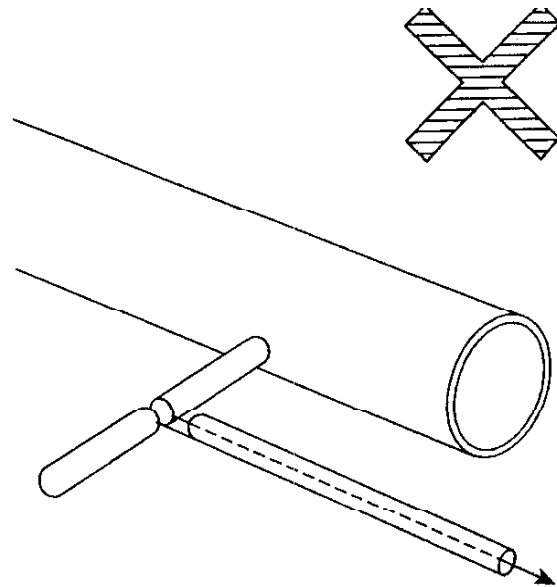

**Figure 6b.** The charge probe with the lead wire parallel to the radiating  $\mathbf{E}$  field.

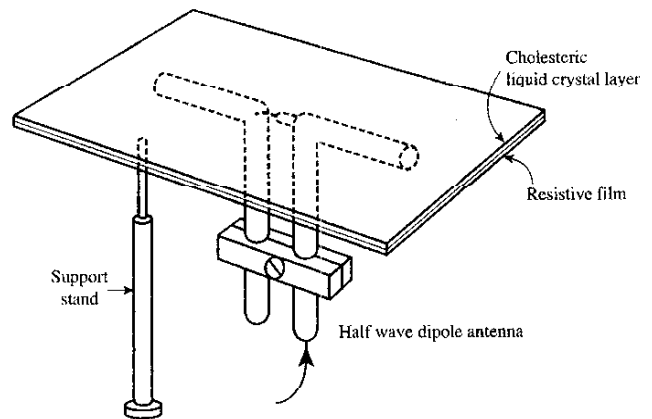

**Figure 7.** Visualization of the Poynting-vector pattern of a half-wave-dipole antenna.

not contribute to the  $\phi$  measurement. The asymmetric shape of the probe in Figure 5b is subject to error, because the  $\mathbf{E}$  field excitation on the left is different from that on the right, which creates a potential difference between a-b.

## 2.2 Charge on the Dipole Antenna

### Discussion of the Experimental Results

**Instructor:** When you used the small dipole antenna shown in Figure 6 to measure the charge distribution, what did you observe?

**Student:** The charges are accumulated toward the tips of the antenna, and they are a minimum at the driving point of the antenna.

**Instructor:** Why is the orientation of the charge probe in Figure 6a better than that in Figure 6b?

**Student:** The orientation of the probe's lead wire shown in Figure 6a is appropriate because it minimizes the excitation of the current on the lead wire due to the radiating  $E$  field. The orientation shown in Figure 6b is not appropriate.

## 2.3 Poynting Vector from the Dipole Antenna

### Discussion of the Experimental Results

**Instructor:** What did the liquid-crystal film reveal about the energy (the Poynting vector) emerging from the dipole antenna?

**Student:** There are three areas of large emission: one in the center, which is the area of highest emission, and two at the tips of the antenna. [Figure 9a is a photograph of a student Mr. Y. Sasaki mapping the Poynting vector, and Figure 9b is a close-up of the liquid-crystal film that was used for the mapping.]

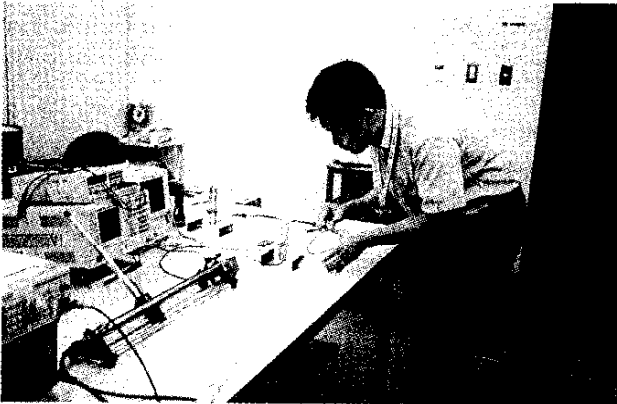

Figure 8. Mr. K. Hara measuring the current on the half-wave dipole.

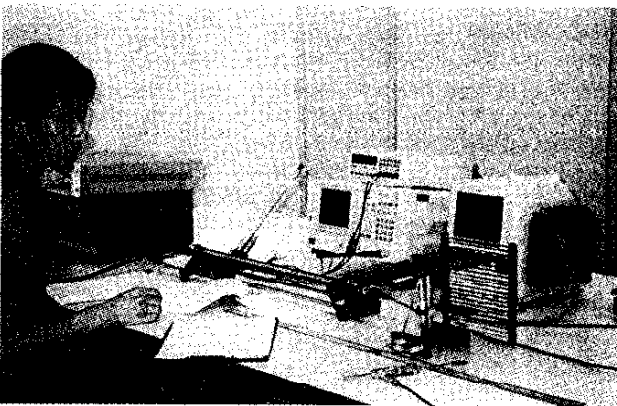

Figure 9a. Mapping the Poynting vector from a half-wave dipole.

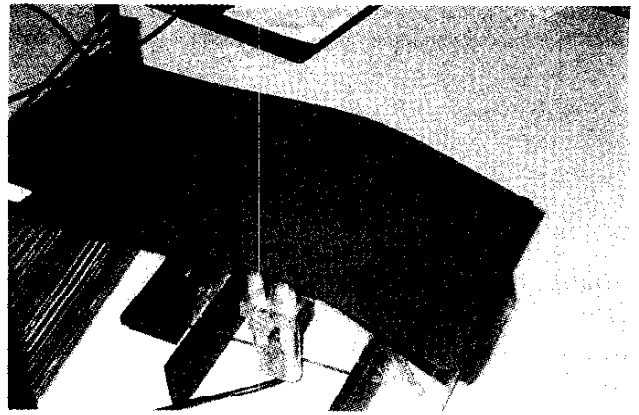

Figure 9b. A close-up of the Poynting vector from a half-wave dipole mapped by a liquid-crystal film.

## 3. Why do Antennas Radiate Radio Waves?

### General Discussion

**Student:** Why do antennas radiate radio waves? Can you give a simple explanation without resorting to complex mathematics and Maxwell's equations?

**Instructor:** You have given me a big challenge. In the topics below, I will do my best to answer your question in the simplest way possible.

### 3.1 Displacement Current

#### General Discussion

**Instructor:** To begin to understand how antennas radiate, it is important to have an understanding of displacement current. Displacement current is closely related to the radiated field in air. The dipole antenna is similar to a thin capacitor plate with one end opened up. Figure 10 shows a circuit in which an ac (alternating current) source is connected to a capacitor by way of an ac ampere meter. Can you tell me if the electrons actually jump across the capacitor?

**Student:** The air space between the capacitor plates acts as an insulator. I would not expect the electrons to jump across the air space because the voltage is not high enough to cause a breakdown of the insulating air space.

**Instructor:** In the instant that the upper terminal of the ac source is positive, positive charges move into the upper capacitor plate and stay there. Positive charges from the source on the way to the capacitor plate go through the ampere meter and deflect the meter's needle. As long as the movement of charges (current) goes

through the meter, the needle of the meter deflects. It does not matter whether or not the charges jump across the capacitor plates. The current registered by the ammeter is the displacement current.

The current that would be registered by the ammeter if the capacitor were replaced by a resistor is the conduction current. The charges of the conduction current actually go across the resistor.

**Student:** Conduction current generates magnetic lines of force around the current. Does the displacement current also generate magnetic lines of force?

**Instructor:** According to Maxwell's equations, the answer is yes. This has important consequences for the propagation of radio waves in air.

We need both the conduction current and the displacement current to explain how the radio wave is generated and then propagates in air. The radio wave can be generated by either conduction current or displacement current, but once the wave is launched into air with zero conductivity, there is no conduction current, just displacement current. The displacement current plays a role in the propagation of the wave.

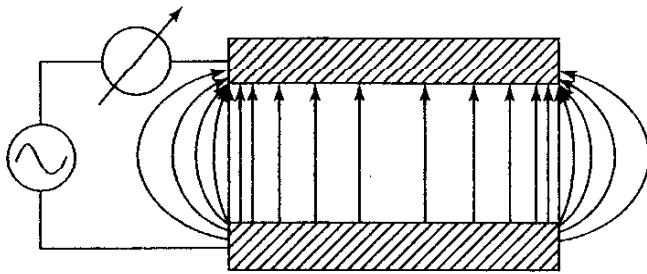

Figure 10a. The electric lines of force around a capacitor.

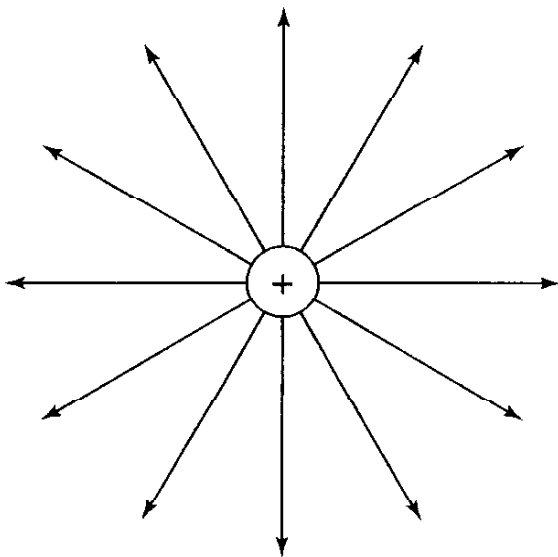

Figure 10b. The electric lines of force from a point charge.

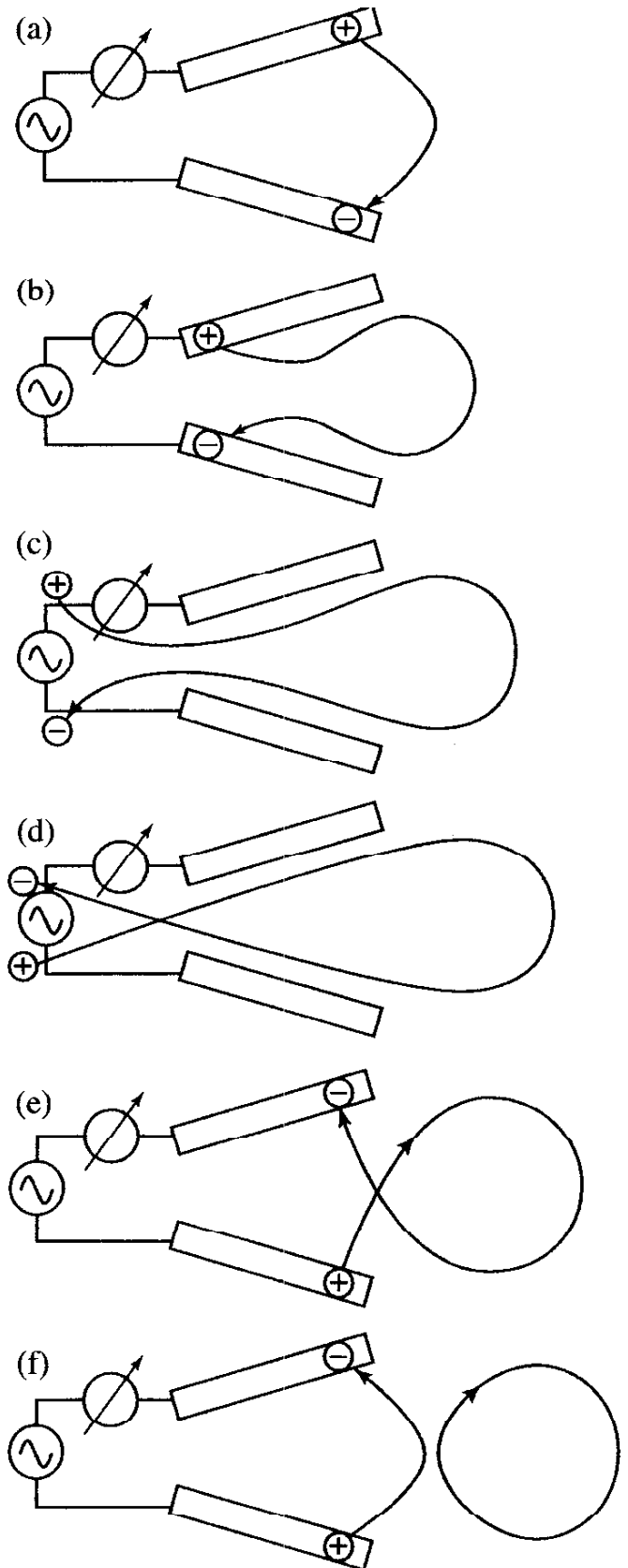

Figure 11. How the radiation takes place from a V antenna.

## 3.2 Emission of the Wave

### General Discussion

**Instructor:** Notice that the electric lines of force bulge out at the ends of the capacitor plate shown in Figure 10a.

**Student:** Why do the lines of force bulge at the ends?

**Instructor:** To answer this question, consider a positive point charge suspended in free space, as shown in Figure 10b. The lines of force of the point charge are spread out evenly in every direction. This pattern can be interpreted as if each outwardly directed line repels the other outwardly directed lines as much as possible. In other words, this interpretation means that the lines of force in the same direction repel each other. Remember this interpretation as we work through the diagrams in the next figure.

Figure 11a shows the case when one side of the capacitor plates is opened. The electric lines of force have more space to bulge out near this opening. The displacement current will certainly continue to flow. Let us focus our attention on the movement of one particular set of positive and negative charges when the polarity of the source is reversed. This is shown sequentially in Figures 11b-11f. The electric lines of force always start from the positive charge and are terminated by the negative charge. As the charge passes through the source, the electric lines of force follow with it, making a loop, as indicated in Figures 11d and 11e. The loop in Figure 11e is equivalent to a bulged line tangent with the loop, as shown in Figure 11f. As mentioned above, two electric lines of force in the same direction repel each other, and a loop of displacement current is launched from the open end of the capacitor. This displacement-current loop in turn generates a time-varying magnetic flux. The time-varying magnetic flux again generates a displacement-current loop. This cycle keeps repeating, and the electromagnetic wave propagates. This is the explanation of how the wave is launched and propagates in air, without resorting to any mathematical formulas.

**Student:** What about the conduction current? Does it contribute to the radiation?

**Instructor:** The answer is very much so. As a matter of fact, any accelerating charge contributes to the radiation. In other



Figure 12. Fleming's shaking rope.

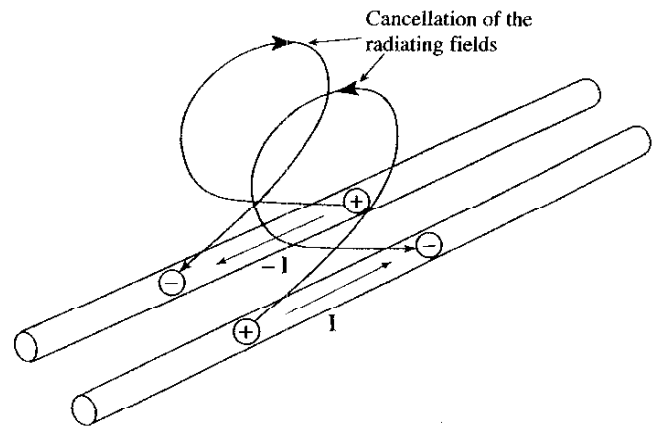

Figure 13a. Radiation from the two-wire line: The cancellation of the radiating fields from the current on the two-wire line.

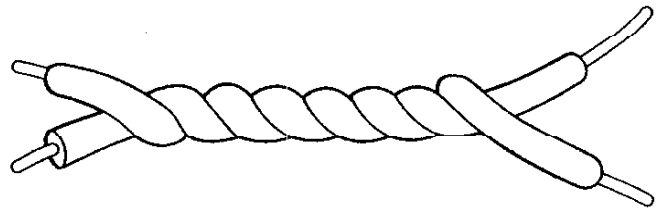

Figure 13b. Radiation from the two-wire line: A twisted cable used to prevent radiation.

words, a dc current consists of charges moving at a constant speed, while an ac current consists of charges undergoing acceleration. Any ac current contributes to the radiation.

Sir John A. Fleming (1849-1946) used to explain electromagnetic-wave phenomena by making analogies with wagging a rope, as pictured in Figure 12. He concluded that the faster he shook the rope, the more distant the wave propagates.

**Student:** Does the current in the feed line cause radiation?

**Instructor:** To answer this question, we must consider not just one feed line, but the pair of feed lines together. As shown in Figure 13a, the currents on the pair of feed wires have equal magnitude, but they run in opposite directions, so that the fields radiated from both wires cancel each other. In other words, the feed wires do not radiate, provided the spacing between the two wires is minimal. As a matter of fact, in order to minimize the radiation from the feed wires, the wires are twisted, as shown in Figure 13b. Twisting makes the contributions of the two feed wires more even, and improves the cancellation. This is a trick used to minimize the radiation from the connecting wires of any electronic circuit.

## 3.3 Length of the Dipole Antenna

### General Discussion

**Instructor:** The experiments you have performed thus far have been mainly concerned with the half-wave dipole antenna. Now we will discuss the effects of the antenna's length by

considering various linear dipole antennas, in addition to the half-wave dipole antenna.

**Student:** Are longer antennas better than shorter antennas?

**Instructor:** Although you might be inclined to think that longer antennas produce stronger fields for the same driving current, the direction of the current on the antenna is reversed at every half-wavelength, and this is not necessarily the case. The length of the dipole antenna has to be determined from considerations such as the desired shape of the radiation pattern, the effort required to match the impedance in driving the antenna, the overall manageability, and the suitability of the physical dimensions for the intended application.

Figure 14 shows how the radiation pattern varies with the length of the dipole antenna. Antennas with a total length that is shorter than one wavelength ( $\lambda$ ) have only one major radiation lobe. Antennas with a length that is longer than  $\lambda$  start having sidelobes, and the direction of the main lobe moves toward the axis of the antenna. The number of sidelobes increases with an increase in antenna length. These sidelobes generally do more harm than good, because the radiation energy is spread over a wide area. When used as a receiving antenna, a long antenna is likely to pick up radio noise coming from directions other than the direction in which the desired wave is coming, and the received signal becomes noisier.

The input impedance of an antenna that has a current minimum at the driving point of the antenna, as in Figures 14b and 14d, becomes awkwardly high, which makes it difficult to achieve a good impedance match for assuring maximum radiated power.

### 3.4 The Function of a Balun

#### General Discussion

**Student:** What does the two-wire line supporting the dipole antenna do?

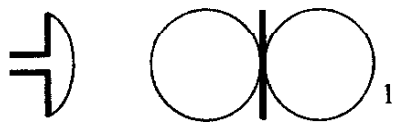

**Figure 14a.** The vertical pattern for a half-wavelength dipole. The current distribution is shown on the side.

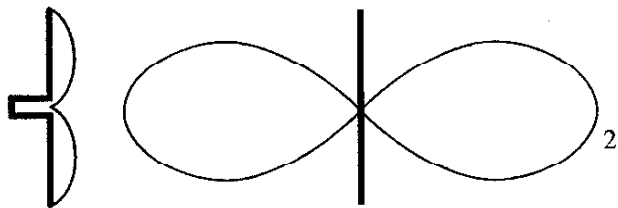

**Figure 14b.** The vertical pattern for a one-wavelength dipole. The current distribution is shown on the side.

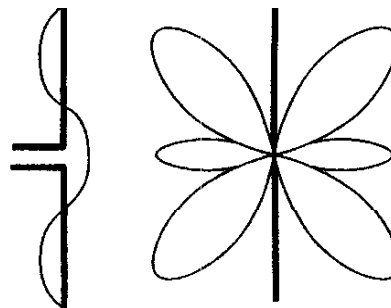

**Figure 14c.** The vertical pattern for a one-and-one-half-wavelength dipole. The current distribution is shown on the side.

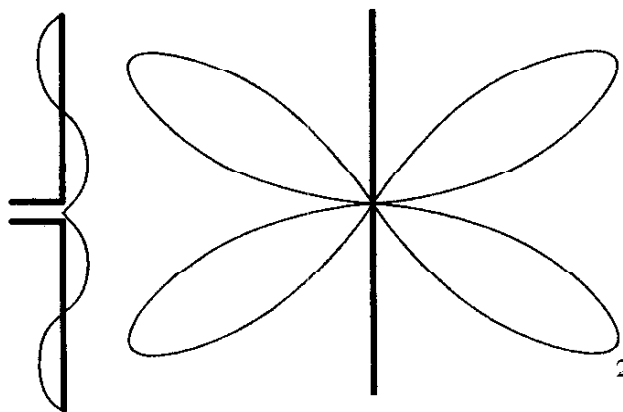

**Figure 14d.** The vertical pattern for a two-wavelength dipole. The current distribution is shown on the side.

**Instructor:** The two-wire line supporting the dipole antenna prevents the current from flowing to the outside surface of the outer conductor of the coaxial cable, and prevents the entire coaxial cable from becoming one big radiating antenna. It also physically supports the dipole, with minimum interference to the dipole. Figure 15 shows the details of the structure, which is called a balun. “Balun” is a word derived from the words balanced and unbalanced. The balun is a device that connects the dipole (which is a balanced structure) with a coaxial cable, which has inner and outer conductors that are asymmetric (which is an unbalanced structure).

The structure consists of a half-wave dipole antenna on the top, and a quarter-wave ( $\lambda/4$ ) short-circuited two-wire line at the bottom. The outer conductor of the coaxial cable is soldered onto a small hole in the half-wave dipole antenna. There is no path from the inner surface of the outer conductor to the outside of the outer conductor of the coaxial cable. Current that has flowed out of the inner surface of the outer conductor has two possible paths: one is to the dipole to excite the dipole as a radiator, and the other is to the short-circuited two-wire line. A butylene insulator covers the coaxial cable, and no current leaks into the outer conductor from the two-wire line.

Next, we consider the current toward the short-circuited two-wire line. The two-wire line is short-circuited at the bottom, and the dipole is connected  $\lambda/4$  from this short. The current on the two-wire line always becomes a maximum at this location of the short circuit. The current at the location one-quarter of a wavelength away from the maximum is always a minimum. Therefore,

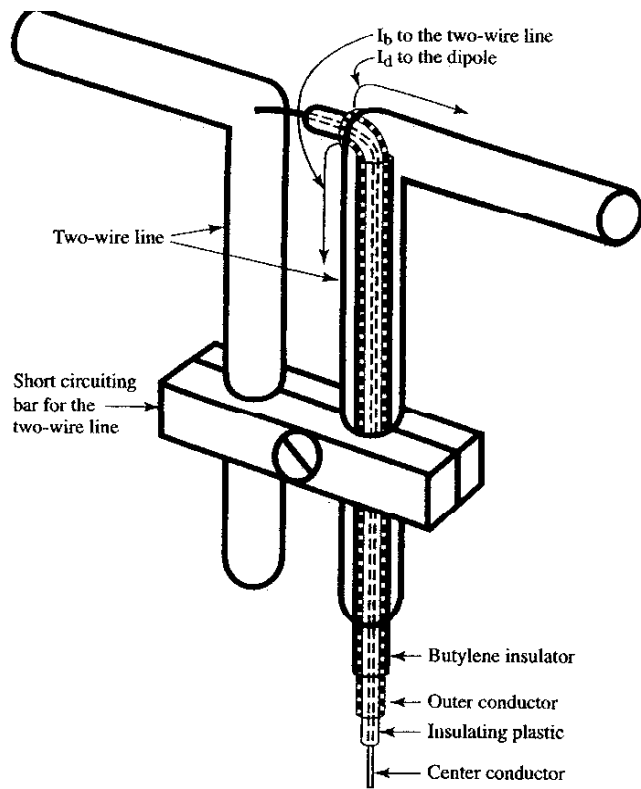

Figure 15. A balun for a dipole antenna.

the two-wire current,  $I_b$ , at the driving point of the dipole is at its minimum. Thus, the impedance,  $V/I_b$ , looking into the two-wire-line is very high, and does not affect the function of the dipole antenna even though physically connected. In conclusion, the balun structure acts as a physical support without interfering with the dipole, and also prevents current from flowing outside the coaxial cable.

## 4 Reflection of the Radio Wave Experiment Instructions

In this experiment, you will study the reflection of the radio wave. The first four steps below deal with the reflection of the **E** field of the radio wave. The last step deals with the reflection of the **H** field.

- Using the arrangement shown in Figure 1, take a piece of a solid aluminum plate and place it behind the receiving antenna, as shown in Figure 16. Find the optimum location that gives the maximum output from the receiving antenna. Why is this location the optimum?
- Compare the reflection of the **E** field using metal rods of various lengths instead of the metal-plate reflector. How do the metal rods compare with the metal plate in terms of their ability to reflect the wave? Is there an optimum rod length that produces a better reflector than other lengths?
- Now use a unidirectionally conducting screen instead of a solid metal plate as the reflector. The screen is made out of metal rods

spaced by a pair of plastic spacers at both ends of the rods, and it resembles a Venetian blind. What orientation of the screen produces the best reflection?

- Can you find other configurations of metal reflectors to enhance the output of the receiver antenna?

To study the **H**-field reflection, switch the receiving antenna to a loop antenna, and find the optimum location of the reflector. For **H**-field reflection, the reflector need not be a perfect conductor. In fact, you can even use plastic as the reflector, although the amount of reflection will be less.

[End of instructions.]

## 4.1 E-Field Reflection from a Solid Metal Plate

### Discussion of the Experimental Results

**Instructor:** Is there an optimum location for maximum reflection of the **E** field from the solid metal plate?

**Student:** Yes. I discovered that the optimum location is  $\lambda/4$  from the receiving antenna.

**Instructor:** The reflected wave travels  $\lambda/4$  to the reflector and comes back another  $\lambda/4$ , for a total delay of  $\lambda/2$  from that of the incident wave. You might expect that these two waves would cancel each other, and that the resultant field would be the lowest (worst reflection) in this case; however, this does not match with the experimental observation. The reason for this seemingly contradictory behavior is that we have neglected to take into account the phase shift on the surface of the reflector.

Let us look at the mechanism of reflection from a perfectly conducting plate. As shown in Figure 17, suppose that the electric lines of force are pointing upward at a particular instant in front of

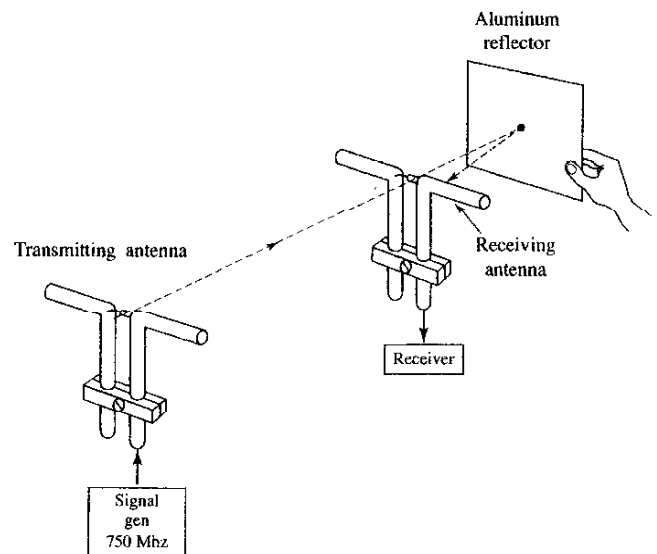

Figure 16. The optimum location for the aluminum-plate reflector.

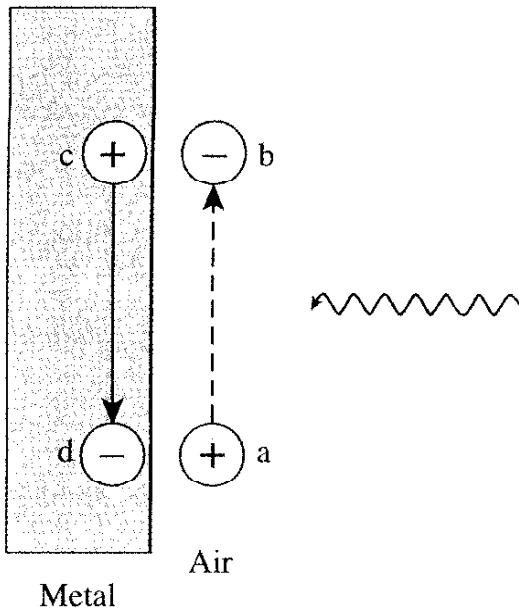

Figure 17a. How the radio wave reflects: reflection of the E field.

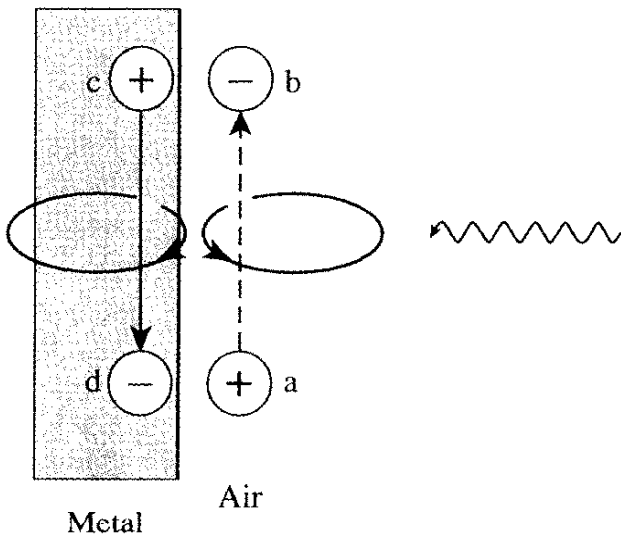

Figure 17b. How the radio wave reflects: reflection of the H field.

the plate. This field is equivalent to placing a positive-polarity plate at the bottom and a negative-polarity plate at the top. Electrons on the surface of the conductor are pushed downward and positive ions appear at the top. This newly created electric field is pointing downward, as shown in Figure 17a. The polarity of the reflected E field, however, is opposite to that of the incident wave. The reflection coefficient,  $R_E$ , of the E field of a perfect conductor is  $R_E = -1$ .

Reflection can be viewed as a re-radiation. The addition of the incident field and the newly created field makes the resultant electric field on the surface of the conductor zero. This is precisely Maxwell's boundary condition. This newly created field on the

conductor becomes a source of re-radiation. The conductor behaves like a receiving antenna, and the excited current turns the conductor into a radiating antenna. The reflection is the re-radiation from the conductor.

Thus, the reflected field has an additional  $180^\circ$  phase shift. The total delay of the reflected wave is  $\lambda/4 + \lambda/4 + \lambda/2 = \lambda$  when the reflector is located  $\lambda/4$  behind the receiving antenna. The incident and reflected wave interfere constructively at the receiving antenna, which explains why the optimum location for the reflector is  $\lambda/4$  behind the receiver.

## 4.2 E-Field Reflection from Metal Rods

### Discussion of the Experimental Results

**Instructor:** How do the metal rods compare to the metal plates as reflectors?

**Student:** The metal rods are not as good reflectors as the plane reflector, but they do behave as reflectors. A longer rod is not necessarily a better reflector than a shorter rod. In particular, a half-wavelength-long rod works almost as good as a plane reflector.

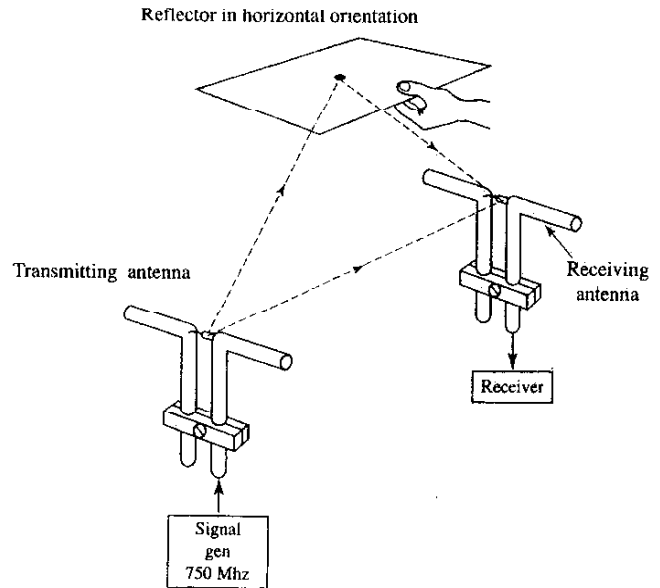

Figure 18a. Reflection from a horizontal plate.

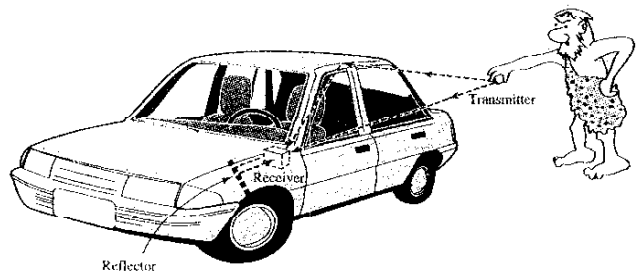

Figure 18b. The multiple paths of a keyless-entry signal: reflections from a car's surfaces.

**Instructor:** The re-radiating current is excited best on a rod of resonant length, which is a multiple of a half-wavelength. On the other hand, it is excited worst on a rod of anti-resonance, which is an odd multiple of a quarter-wavelength. This is one of the reasons why we chose a half-wavelength as the length of the reflector antenna.

### 4.3 E-Field Reflection from a Unidirectional Conducting Screen

#### Discussion of the Experimental Results

**Instructor:** Did the unidirectional conducting screen reflect the  $E$  field?

**Student:** The amount of reflection depended on the orientation of the screen. In certain orientations, the screen did not reflect at all.

**Instructor:** When the screen is oriented so that the conductors in the screen are perpendicular to the direction of polarization of the incident wave, there is no reflection. When the screen is oriented so that the conductors are parallel to the direction of polarization of the incident wave, the screen becomes a good reflector.

This confirms the earlier explanation of the reflection as re-radiation from the reflector. If the conductors are parallel to the polarization direction of the incident wave, the conductors behave as a receiving antenna array, and the excited currents convert the receiving antenna array into a radiation antenna array. This behavior produces a good reflector. On the other hand, when the conductors are perpendicular to the polarization direction of the incident wave, the conductors do not behave like an array of receiving antennas, and the screen does not reflect.

### 4.4 E-Field Reflection from Other Configurations

#### General Discussion

**Instructor:** Parabolic reflectors with large diameters, which are used as outdoor rotating-dish antennas, have to withstand wind storms. In order to lighten the air pressure, the reflector dish is often made out of metal mesh.

Another use for metal mesh is as strength members in the construction of a plastic radome, by orienting the metal wires perpendicular to the incident wave. A radome is a large sphere used to cover the entire outdoor reflector dish.

For the application of keyless entry to an automobile, the system can be designed so that reflection from the metallic surfaces of the automobile enhances the received signal. As shown in Figure 18b, the received signal is enhanced when the wave reflected from the ceiling, floor, or side doors of the vehicle is in phase with the wave arriving directly at the receiving antenna. You can mimic this configuration in the lab by using a horizontal reflector surface, as shown in Figure 18a.

**Student:** Yes, I see. As I change the height of the horizontal reflector surface, the received signal passes through a maximum, minimum, maximum, and so on.

**Instructor:** Another example is a reflector tower on top of a mountain for connecting microwave-relay stations. In this case, there is no direct wave, but the idea of using a reflector is the same. To be more exact, consideration of the polarization of the interfering waves has to be included.

### 4.5 H-Field Reflection from an Arbitrary Reflector

#### Discussion of the Experimental Results

**Instructor:** Is there an optimum location for maximum reflection of the  $H$  field from a reflector?

**Student:** Yes. I discovered that the received signal is at a maximum when the loop receiving antenna is right on the reflector. This is different from that of the dipole receiving antenna.

**Instructor:** As shown in Figure 17b, there are two displacement-current elements, a-b and c-d, of equal magnitude but in opposite directions. Due to Ampere's law, each current element establishes a circular magnetic flux with the sense of rotation in opposite directions. The magnetic-flux density in the area between the current elements (on the surface of the reflector) becomes double.

In other words, the contributions of a-b and c-d to the magnetic flux are in phase. The reflection coefficient,  $R_H$ , of a perfect

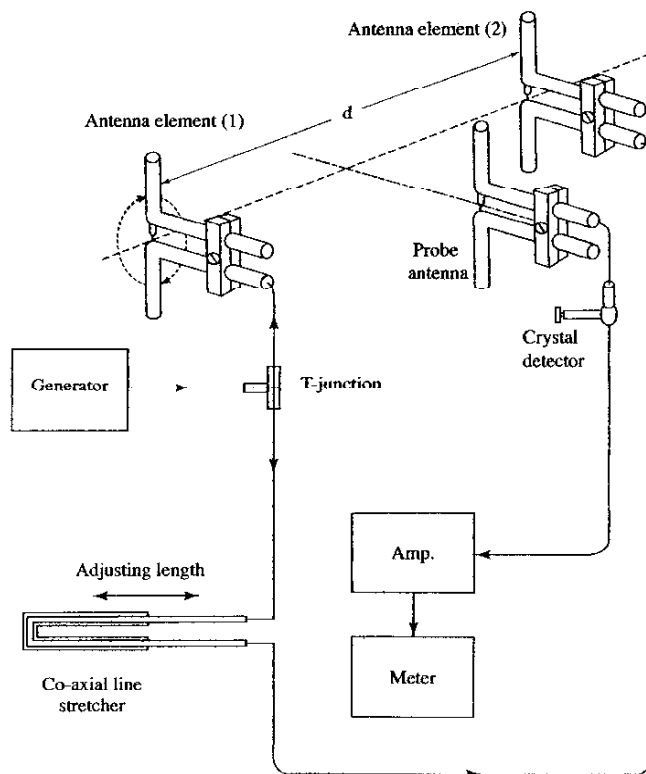

Figure 19. A two-element antenna array.

conductor is  $R_H = 1$ . Compared to the  $\mathbf{E}$ -field reflection,  $R_E = -R_H$ . It is noteworthy that this relationship is true regardless of the material of the reflector, be it a perfect conductor, or even plastic.

Thus, the optimum location for the  $\mathbf{H}$ -field reflector is when the loop receiving antenna is on the surface of the reflector. Good  $\mathbf{H}$ -field reflection is also obtained when the reflector is located  $\lambda/2$  away from the loop receiving antenna.

## 5. Steering an Antenna Array Pattern

### Experiment Instructions

By manipulating the relative phase of the element antennas, the shape and the direction of the radiation lobe can be steered. In this experiment, you will explore various antenna array patterns by following these steps:

1. As shown in Figure 19, connect two transmitting dipole antennas to a generator: one straight to a dipole antenna (1), and the other by way of a (trombone) coaxial-line stretcher. The coaxial-line stretcher is used to change the physical length of the coaxial cable and, hence, to change the phase of the driving point of the dipole antenna (2).

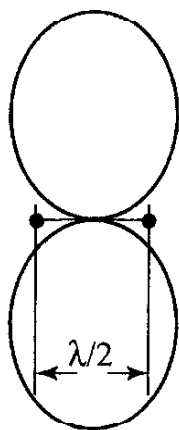

Figure 20a. The radiation pattern of the two-element array with spacing  $d = \lambda/2$  and relative phase  $\phi = 0^\circ$  of the driving currents of the antenna elements.

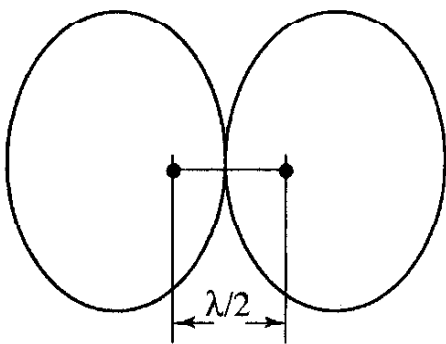

Figure 20b. The radiation pattern of the two-element array with spacing  $d = \lambda/2$  and relative phase  $\phi = 180^\circ$  of the driving currents of the antenna elements.

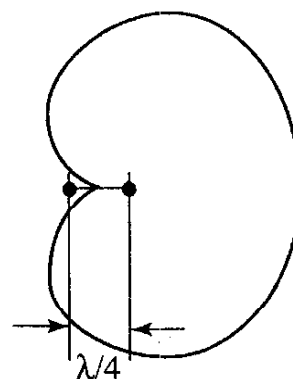

Figure 20c. The radiation pattern of the two-element array with spacing  $d = \lambda/4$  and relative phase  $\phi = 90^\circ$  of the driving currents of the antenna elements.

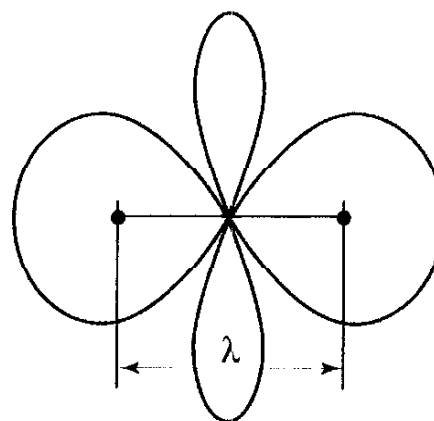

Figure 20d. The radiation pattern of the two-element array with spacing  $d = \lambda$  and relative phase  $\phi = 0^\circ$  of the driving currents of the antenna elements.

2. Figure 20 shows a number of radiation patterns that you can achieve with the two-element antenna array, by adjusting the spacing between the elements and by adjusting the phase via the coaxial-line stretcher. The radiation pattern in Figure 20a is an example of a broad-side radiation pattern, which is characterized by radiation lobes that lie in a direction perpendicular to the array's axis. The radiation patterns in Figures 20b and 20c are examples of end-fire radiation patterns, which are characterized by radiation lobes that lie in the direction of the array's axis. If time permits, experiment with generating all of the radiation patterns shown in Figure 20. If you are short of time, generate the broad-side array pattern in Figure 20a first, and then make adjustments to the spacing and phase to convert it into the unidirectional end-fire array pattern in Figure 20c. When generating the radiation patterns, use your probe antenna (see Figure 19) to verify that you have achieved the desired results.

[End of instructions.]

### 5.1 Broadside Array

#### Discussion of the Experimental Results

**Instructor:** How did you produce the broadside array pattern?

**Student:** I adjusted the spacing between the antenna elements so that they were  $\lambda/2$  apart. I then inserted a probe dipole antenna on the line that bisects the two array elements, as shown in Figure 19. To find the broadside radiation lobe, I adjusted the length of the coaxial-line stretcher, searching for the maximum output from the probe dipole antenna.

**Instructor:** There are two approaches that you can use to produce a broadside radiation pattern from the two-element array. One approach is the method that you just described, which is to use the configuration shown in Figure 19 and adjust the coaxial-line stretcher until the maximum output from the probe antenna is obtained. The other approach is to modify the configuration in Figure 19 to search for null output instead of the maximum output. Searching for a null output is usually easier than searching for the maximum output because the nulls are sharper.

**Student:** How do I modify the configuration to search for a null output?

**Instructor:** To produce a broadside radiation pattern using a null output, rotate one of the antenna elements by  $180^\circ$  about the feed line, as indicated by the rotating arrows in Figure 19. Adjust the coaxial-line stretcher until the output from the probe antenna is a null. Rotate the antenna element back to its original position, and move the probe antenna around to verify the broadside radiation lobes.

## 5.2 End-Fire Array

### Discussion of the Experimental Results

**Instructor:** The most challenging of the radiation patterns shown in Figure 20 is the unidirectional end-fire array, shown in Figure 20c. The radiation takes place in the direction of the axis of the array, and moreover with only one radiation lobe. What adjustments did you make to the broadside array of Figure 20a to convert it to the unidirectional end-fire array of Figure 20c?

**Student:** When I set up the broadside array, I spaced the array elements by  $\lambda/2$ . In order to convert the broadside array pattern into a unidirectional end-fire pattern, I first reduced the spacing between the antenna elements from  $\lambda/2$  to  $\lambda/4$ . Then, I adjusted the coaxial-line stretcher to change the length by  $\lambda/4$ . In my setup, the wavelength  $\lambda$  is 40 cm, and  $\lambda/4 = 10$  cm. I used my probe antenna to verify that a lobe exists on one side of the array but not on the other side.

**Instructor:** If you wanted to switch the position of the lobe from one side to the other, how could you achieve this?

**Student:** I am guessing that this might be possible by changing the phase, but I am not sure how much of a phase change is required. Can you explain?

**Instructor:** Empirically, you may have discovered that reversing the direction of the radiation lobe can be achieved by further stretching by  $\lambda/2$ . The next subsection explains the reasons why.

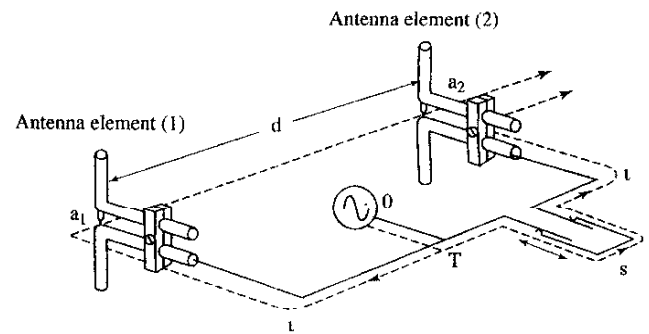

**Figure 21a.** The principle of operation of the unidirectional end-fire array: Finding the paths of the wave from the T junction to  $a_2$ .

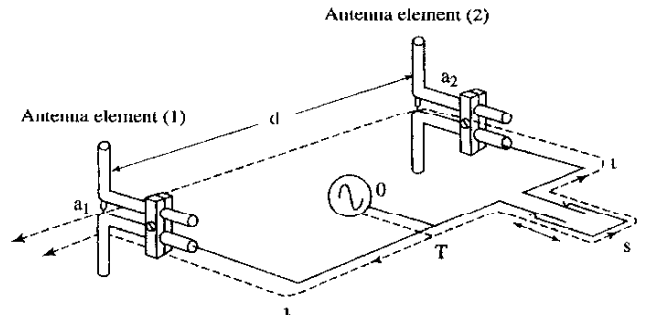

**Figure 21b.** The principle of operation of the unidirectional end-fire array: Finding the paths of the wave from the T junction to  $a_1$ .

## 5.3 Generalization of Array Pattern Rules

### General Discussion

**Student:** I succeeded in producing the unidirectional end-fire array pattern using the instructions in the experimental setup, but I would like to learn more. What is the principle of operation of the unidirectional end-fire array? How much of a phase change is required to reverse the direction of the radiation lobe?

**Instructor:** We will use Figure 21 to explain the principle of operation of the unidirectional end-fire array. Pick an arbitrary point in the field, let us say point  $a_2$  in Figure 21a. The wave path from the source to point  $a_2$  by way of one antenna element is compared with the same by way of the other antenna element. Figure 21a shows the case when the point of observation is taken to the right of the antenna array. The distance between the two antenna elements is  $d$ . Let us say the T junction from the generator is placed exactly at the midpoint between the two elements. The midpoint is chosen for convenience; in practice, the T can be placed at other locations (such as in Figure 19) because the same phenomenon repeats itself every wavelength. From T to  $a_2$  by way of the coaxial-line stretcher is  $l+s$ . From T to  $a_2$  by way of  $a_1$  and free-space propagation is  $l+d$ , and hence the difference in the path is  $\Delta p = s-d$ . When both the spacing,  $d$ , between the antenna

elements and the length of the coaxial-line stretcher are set to  $s = \lambda/4$ , then  $\Delta p = 0$  and the two wave paths become equal. The waves from the two paths constructively interfere, and the radiation to the right of the antenna array becomes a maximum. This is the case shown in Figure 20c.

Figure 21b shows the case when the point of observation is taken to the left of the antenna array. From T to  $a_1$  is  $l$ . From T to  $a_1$  by way of the coaxial-line stretcher and free-space propagation is  $l + s + \lambda/4$  (with  $d = \lambda/4$ ), and hence the difference in the path is  $\Delta p = s + \lambda/4$ . When the length of the coaxial-line stretcher is set to  $s = 3\lambda/4$ , then  $\Delta p = \lambda$ . Waves from the two paths interfere constructively, and the radiation to the left of the antenna array becomes a maximum. This reverses the direction of the radiation lobe.

**Student:** Yes, I see. Now I understand how to adjust the length of the stretcher to reverse the direction of the radiation lobe. Is there a way to do this electronically?

**Instructor:** With an electronic phase shifter, the radiation lobe can be swung swiftly by changing the phase electronically. Such an array is called a phased array. It has been used as a radar antenna to catch such fast-moving targets as intercontinental ballistic missiles.

## 6. Acknowledgements

I would like to express my special appreciation to Mr. Hiroki Toyama, Shoji Mahune, and Kei-ichi Nagayama of Omron Corporation, Komaki, Japan for their preparation of the laboratory setups. I also express my heart-felt thanks to Mrs. Mary Jean Giliberto, who has not only given various suggestions, but also polished the manuscript to the present form. ☺



### Editor's Comments *Continued from page 58*

the wages paid for the same work are substantially lower – has become a topic of considerable debate in the US, and it is being discussed in Europe and some parts of Asia, as well. Of course, it can become very personal when the jobs involved are electrical engineering jobs. Furthermore, what represents a loss of jobs for one country can represent a significant gain in jobs for another. Thus, whether it is perceived as a problem or a benefit often depends on the job market in the country in which you are trying to sell your services. If you are in a country that is seeing a significant number of its engineering jobs moving to other countries, you may view outsourcing as a threat to your livelihood – or as motivation to make sure that your education and skills are such as to adequately justify the salary and job security you have, or want. If you are in a country to which jobs are being outsourced, you may view outsourcing as an affirmation of the value of such services in your country.

Regardless of the effect on our profession, I have noted what I think is a definite, disturbing trend from a consumer's point of view in dealing with companies that have outsourced certain services, particularly sales and technical support. Two prime examples with which I have recently been dealing are CompuServe and Gateway, although I have encountered similar experiences with a number of other companies. I have started asking where the

people I am talking with are located when I have recently had to deal with technical and sales support from these and other companies. I've often been told that the person I'm dealing with is in another country, and that the function has been outsourced. In almost all such cases – and particularly when I'm dealing with a company where the function previously was handled by support staff under more-direct corporate control – my experience is that the outsourced support people are incapable of doing much more than following a script. If your needs happen to fall within the range of one of the standard scripts the person has apparently been given for handling that problem or sales situation, then the support is fine. If not, there effectively is no support possible. I use the term "script" because I have actually had the experience of calling at different times with the same problem, ending up with different support people, and being asked questions and being given answers that were almost word-for-word the same. My experience has also been that at least some of these people are incapable of responding in a rational – let alone, knowledgeable – fashion if you insist on asking questions or giving them information that departs from their script. This is in sharp contrast to my prior experience with non-outsourced support from the same companies, where it appeared that the support people actually had a reasonable level of understanding of the product or service for which they were providing support. Also, it used to be possible to get to a more-experienced person if the problem you had went beyond the knowledge or experience of the person with whom you were initially dealing. That now seems to be impossible.

In fairness, some of this may have been caused because the function had only recently been outsourced: experience and understanding come with time. However, the net effect on me as a consumer has been to make the value of the support associated with the product or service I have purchased (or was considering purchasing) next to worthless (actually, given the resulting aggravation, it is less than worthless). The result is that I won't purchase that product or service from such companies again, if I can avoid doing so – and over the long term, that certainly negates any savings the company may have realized by outsourcing the support function.

I should also add that there are undoubtedly outsourcing contractors who provide excellent, well-trained support personnel. I simply haven't experienced any. Of course, if they are quite good (and won't identify themselves as being part of an outsourced function), I wouldn't know that the function had been outsourced. If a company is going to outsource a support function, it is obviously critical that the company put sufficient quality-control procedures in place to insure that the value to the consumer is maintained. Well, that may be obvious to we consumers who have had negative experiences, but it apparently hasn't been obvious to some of the companies doing the outsourcing!

There is another aspect to all of this that is troubling, and for which I don't have an answer. I originally saw this pointed out by Martin Winston, editor of *Newstips*, an electronic newsletter for journalists writing about technology. Dealing with telephone or Web-based support functions located in countries other than your own may have potential legal implications. The laws regarding the handling of personal and credit-card information in the country where the person handling the outsourced sales or support function you are using is located may not be anything like the laws in your country. Of course, it's not uncommon to have international business dealings. However, you usually know when you dealing across borders. That may not be the case in a world where the outsourcing of service or sales support is common.

*Continued on page 112*