

Detectors and Mixers

- Microwave diodes are most commonly used as a nonlinear element, but transistors can also be used
- Figure shows three basic frequency conversion functions: rectification, detection, and mixing.

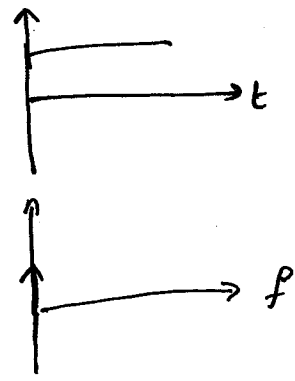

Rectifier

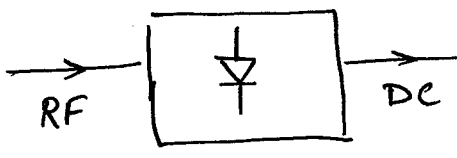
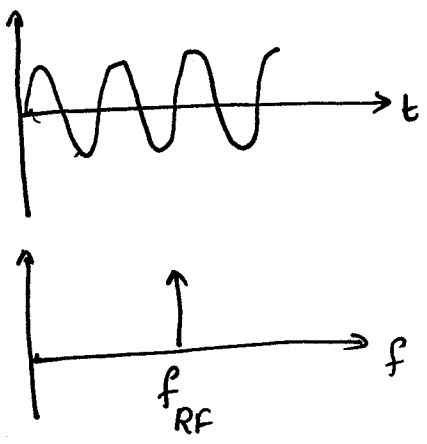
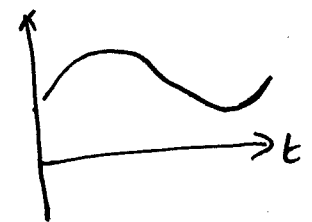
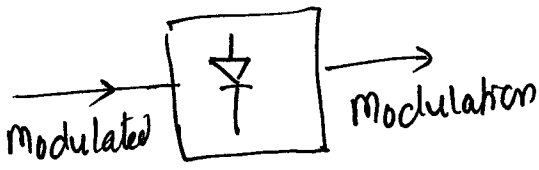
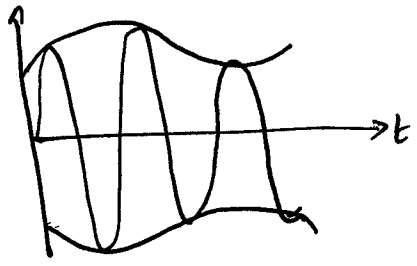

Diode Detector

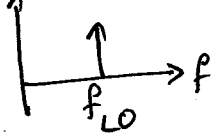
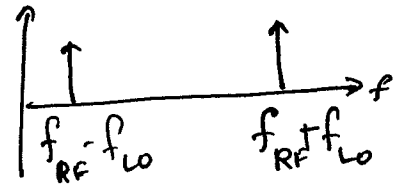
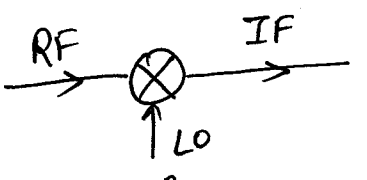
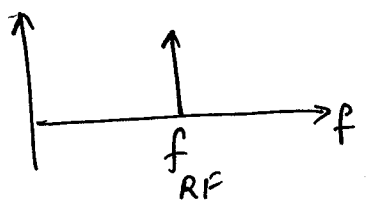

Mixer

Diode Rectifiers and Detectors

→ A diode is basically a nonlinear resistor, with a DC V-I characteristic that can be expressed as:

$$I(V) = I_s (e^{\alpha V} - 1) \quad - (1)$$

$$\alpha = \frac{q}{nKT}$$

q → charge of an electron k - Boltzmann's constant

T → Temperature I_s - saturation current

n → ideality factor

Typically I_s is between 10^{-6} and 10^{-15} A

$\alpha = \frac{q}{nKT}$ is approximately $\left(\frac{1}{25\text{mV}}\right)$ for $T = 290\text{K}$

→ 'n' depends on the structure of the diode itself, and can vary from 1.2 for Schottky barrier diodes to about 2.0 for point-contact silicon diodes.

→ Typical diode V-I characteristics is shown in figure below

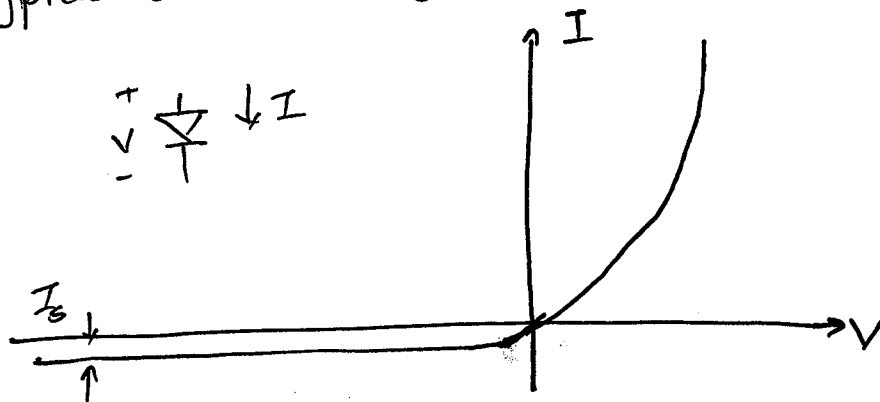

The diode voltage can be defined as:

$$V = V_0 + v \quad (2)$$

$V_0 \rightarrow$ DC bias voltage

$v \rightarrow$ small AC signal voltage

Expanding (1) we get

$$I(V) = I_0 + v \left. \frac{dI}{dV} \right|_{V_0} + \frac{1}{2} v^2 \left. \frac{d^2 I}{dV^2} \right|_{V_0} + \dots \quad (3)$$

where $I_0 = I(V_0)$ is the DC bias current. The first derivative can be evaluated as:

$$\left. \frac{dI}{dV} \right|_{V_0} = \left. \frac{dG_d}{dV} \right|_{V_0} \alpha I_s e^{\alpha V_0} = \alpha (I_0 + I_s) = G_d = \frac{1}{R_j} \quad (4)$$

$R_j \rightarrow$ junction resistance of the diode.

$G_d = \frac{1}{R_j} \rightarrow$ dynamic conductance of the diode.

$$\left. \frac{d^2 I}{dV^2} \right|_{V_0} = \left. \frac{dG_d}{dV} \right|_{V_0} = \alpha^2 I_s e^{\alpha V_0} = \alpha^2 (I_0 + I_s) = \alpha G_d = G_d' \quad (5)$$

Then (3) can be written as:

$$I(V) = I_0 + i = I_0 + v G_d + \frac{v^2}{2} G_d' + \dots \quad (6)$$

The three-term approximation for the diode current is called the small-signal approximation.

- The small-signal approximation is based on the DC voltage-current relationship of (1), and shows that the equivalent circuit of a diode will involve a nonlinear resistance.
- The AC characteristics of a diode also involve reactive effects due to the structure and packaging of the diode.
- A typical equivalent ckt for a diode is shown in

figure below

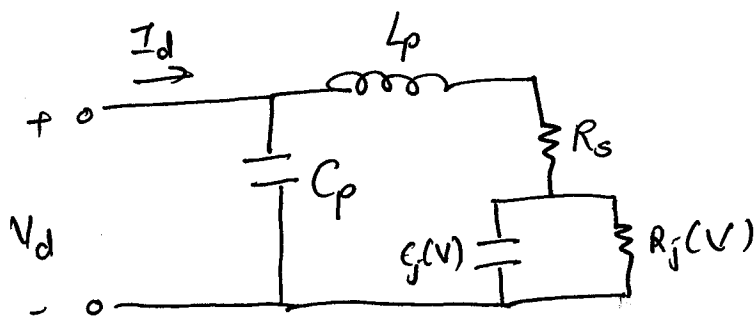

- Leads and contacts of diode package lead to a series inductance, L_p , and shunt capacitance, C_p .

- The series resistance, R_s , accounts for contact and current-spreading resistance

- C_j and R_j are the junction capacitance and resistance, and are bias dependent

Rectifier

- In a rectifier application, a diode is used to convert a fraction of an RF i/p signal to DC power.
- Rectification is a very common function, and is used for power monitors, automatic gain control circuits, and signal strength indicators.
- If the diode voltage consists of a DC bias voltage & a small-signal RF voltage

$$V = V_0 + v_0 \cos \omega t \quad \text{--- (7)}$$

Then (6) can be written as,

$$I = I_0 + v_0 G_D \cos \omega_0 t + \frac{v_0^2}{2} G_D' \cos^2 \omega_0 t \quad \text{--- (8)}$$

$$= I_0 + \frac{v_0^2}{4} G_D' + v_0 G_D \cos \omega_0 t + \frac{v_0^2}{4} G_D' \cos 2\omega_0 t$$

I_0 - bias current and $\frac{v_0^2}{4} G_D'$ is DC rectified current.

The o/p also contains AC signals of frequency ω_0 , and $2\omega_0$ which are usually filtered out with a simple low-pass filter.

- A current sensitivity, β_i , can be defined as a measure of the change in DC output current for a given i/p RF power.

From (6) RF i/p power is $\frac{V_0^2 G_D}{2}$ while (8) shows the change in DC current is $\frac{V_0^2 G_D'}{4}$. The current sensitivity is then

$$\beta_i = \frac{\Delta I_{dc}}{P_{in}} = \frac{G_D'}{2G_D} \text{ A/W} \quad - (9)$$

An open circuit voltage sensitivity, β_v , can be defined in terms of the voltage drop across the junction resistance when the diode is open-circuited.

$$\beta_v = \beta_i R_j \quad - (10)$$

Typical values for the voltage sensitivity of a diode range from 400 to 1500 mV/mW.

In a detector application the nonlinearity of a diode is used to demodulate an amplitude modulated RF carrier.

The diode voltage can be expressed as:

$$v(t) = V_0 (1 + m \cos \omega_m t) \cos \omega_c t \quad - (11)$$

$\omega_m \rightarrow$ modulation frequency

$\omega_c \rightarrow$ RF carrier frequency ($\omega_c \gg \omega_m$)

$m \rightarrow$ modulation index ($0 < m < 1$)

Using (11) & (8) we get expression for $i(t)$

Figure below plots the frequency spectrum of the output signal.

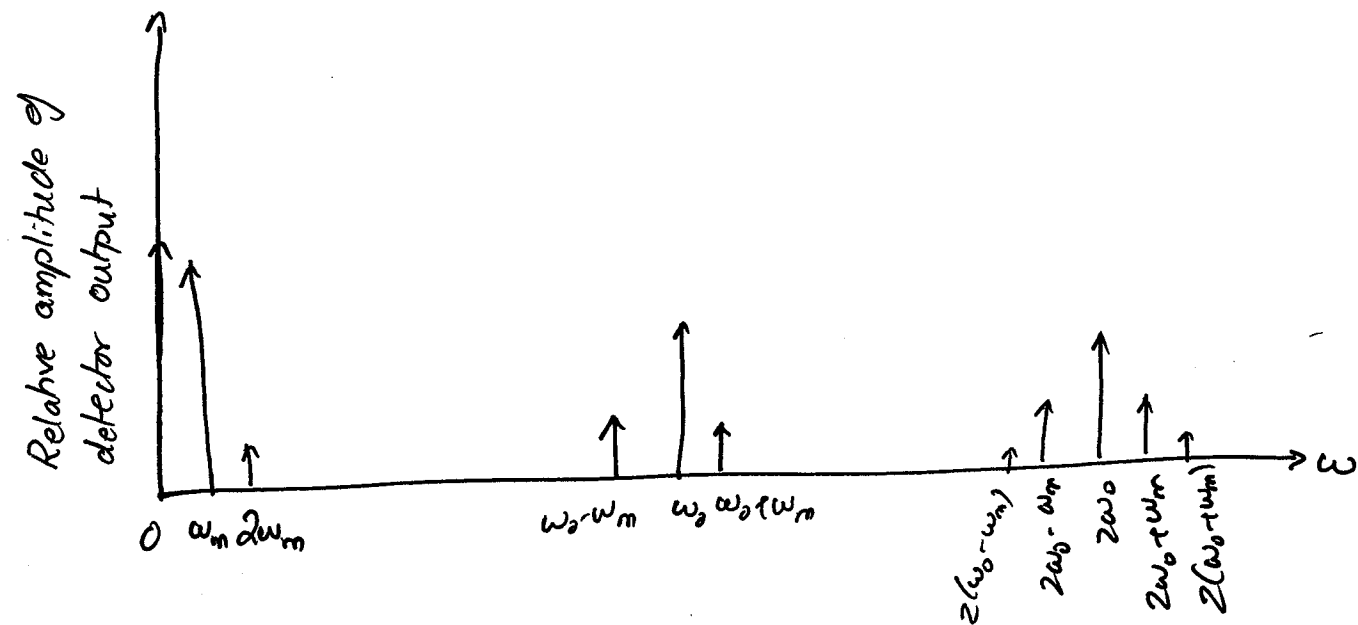

- The o/p current terms which are linear in the diode voltage (terms multiplying $V_0 G_d$) have frequencies of ω_0 and $\omega_0 \pm \omega_m$, while the terms that are proportional to the square of the diode voltage (terms multiplying $V_0^2 G_d' / 2$) include the following frequencies & relative amplitudes

Frequency	Relative Amplitude
0	$1 + m^2/2$
ω_m	$2m$
$2\omega_m$	$m^2/2$
ω_0	$1 + m^2/2$
$2\omega_0 \pm \omega_m$	m
$2(\omega_0 + \omega_m)$	$m^2/4$

- The desired demodulated output of frequency ω_m is easily separated from the undesired components with a low pass filter.
- The amplitude of this current is $m v_o^2 G_d / 2$ which is proportional to the power of the input signal.
- This square law behavior is the usual operating condition for detector diodes, but can be obtained only over a restricted range of input powers.
- If ip power is too large, small signal conditions will not apply, and the output will become saturated and approach a linear, and then a constant, i versus P characteristic.
- At very low signal levels the ip signal will be lost in the noise floor of the device.

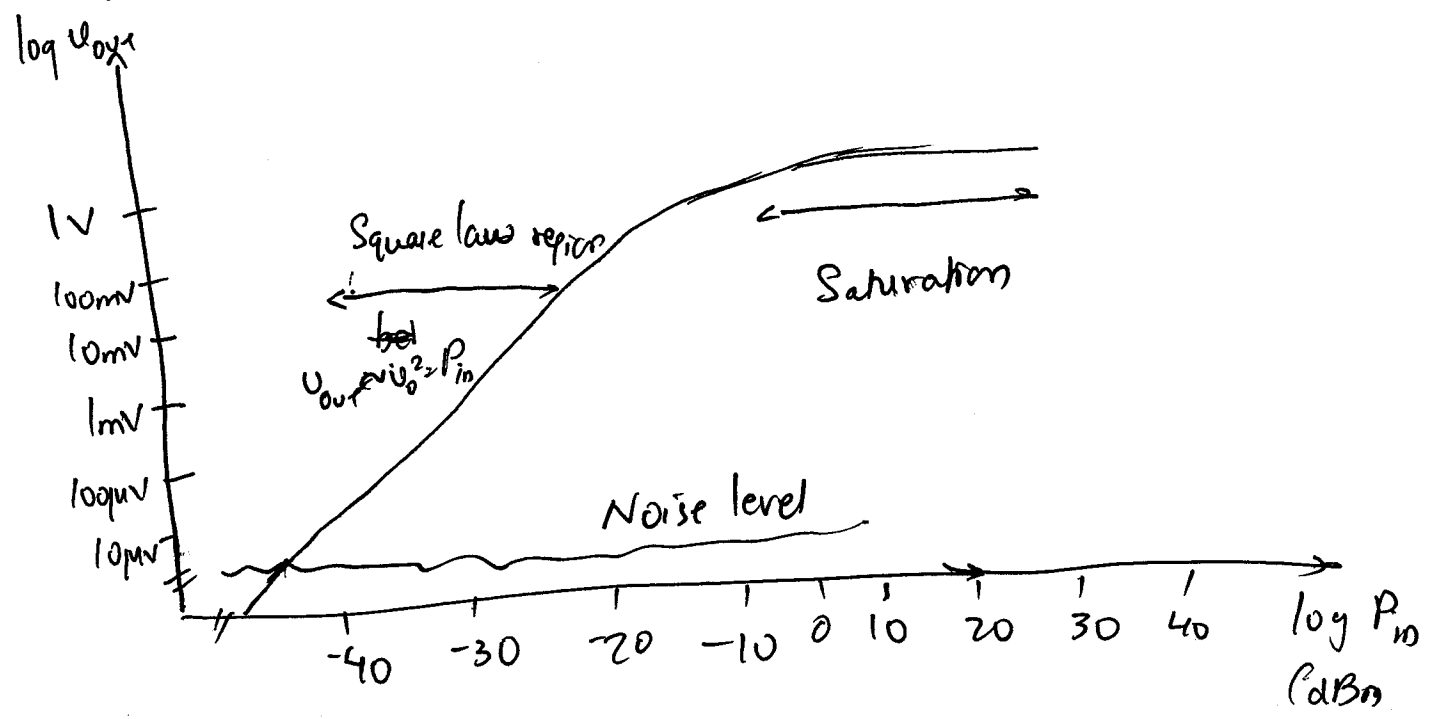

Square law operation is particularly important for applications where power levels are inferred from detector voltage, as is SWR indicators and signal level indicators.

- Detectors may be DC biased to an operating point that provides the best sensitivity.

Single-Ended Mixer

- Mixer uses the nonlinearity of a diode to generate an output spectrum consisting of the sum & difference frequencies of two input signals.
- In RF receiver application, a low-level RF signal and an RF local oscillator (LO) signal are mixed together to produce an intermediate frequency (IF), $f_{IF} = f_{RF} - f_{LO}$ and a much higher frequency $f_{RF} + f_{LO}$ which is filtered out. IF signal has a frequency between 10 and 100 MHz and can be amplified with a LNA.
- This is called a heterodyne receiver, and is useful because it has much better sensitivity and noise characteristics.

than the direct detection schemes.

- A heterodyne system also has the advantage of being able to tune over a band by simply changing the LO frequency, without the need for a high-gain, wideband RF amplifier.

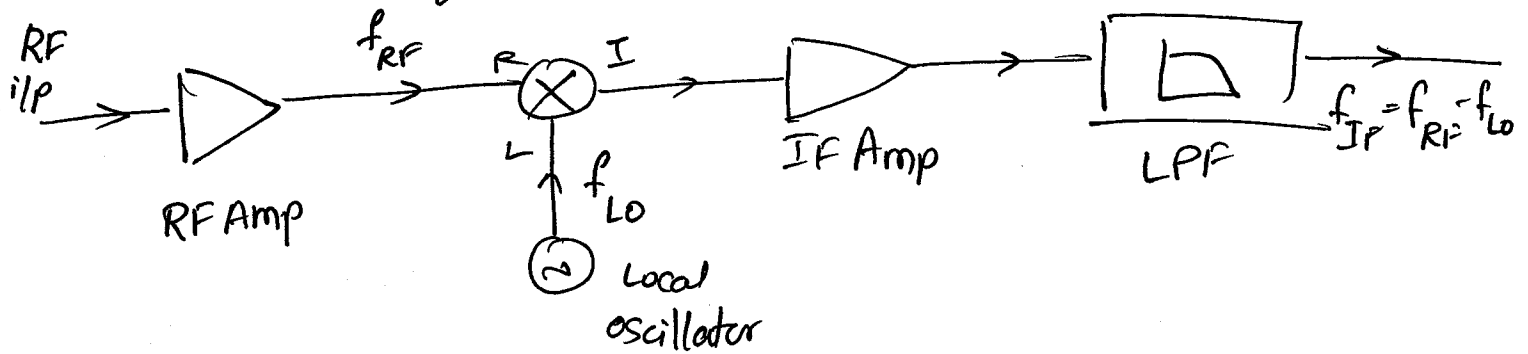

Down-conversion in a heterodyne Receiver.

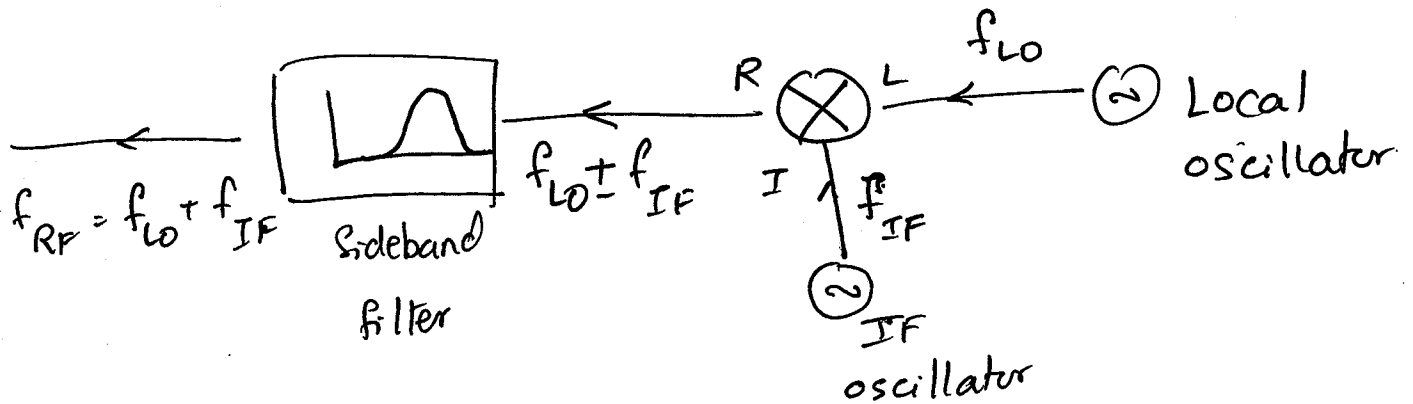

Up-conversion in a transmitter

An example of a single-ended mixer is shown in figure below

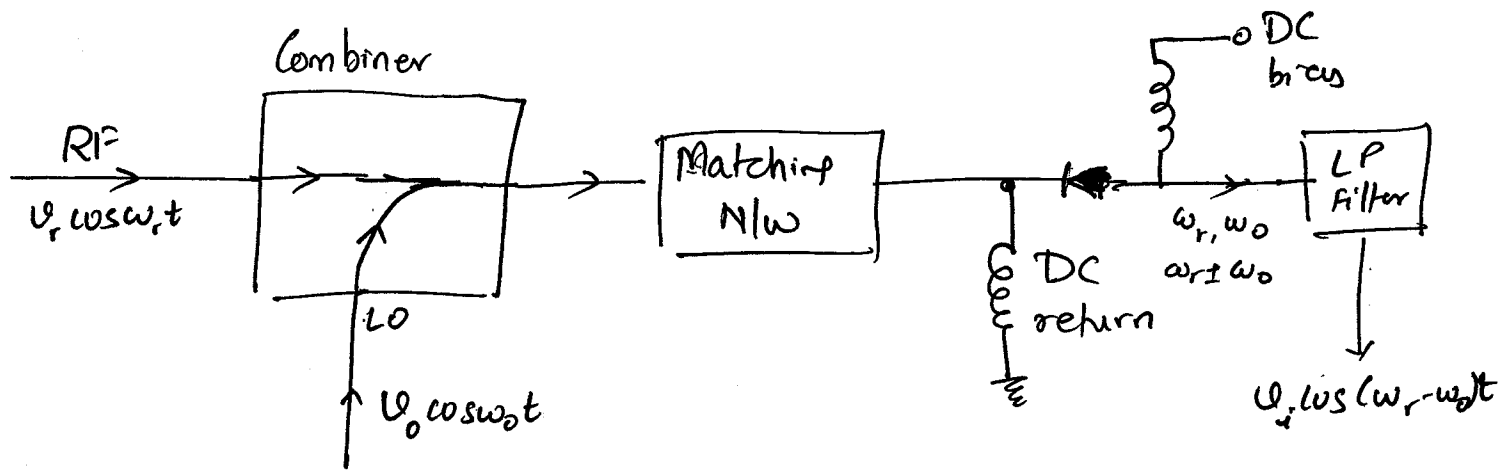

The RF signal

$$U_{RF} \cos \omega_r t$$

is combined with LO signal

$$U_{LO} \cos \omega_o t$$

& is fed into the diode.

The combiner can be a simple T-junction combiner or a directional coupler.

An RF matching circuit may precede the diode, and the diode may be biased through a choke and allow DC to pass while blocking RF.

The diode current will consist of a ^{constant} DC bias term, and RF & LO

signals of frequencies ω_r & ω_o due to the term which is linear in v . The v^2 term will give rise to following o/p current

$$\begin{aligned}
 i &= \frac{G_D'}{2} (v_r \cos \omega_r t + v_o \cos \omega_o t)^2 \\
 &= \frac{G_D'}{2} (v_r^2 \cos^2 \omega_r t + 2v_r v_o \cos \omega_r t \cos \omega_o t + v_o^2 \cos^2 \omega_o t) \\
 &= \frac{G_D'}{4} [v_r^2 + v_o^2 + v_r^2 \cos 2\omega_r t + v_o^2 \cos 2\omega_o t + 2v_r v_o \cos(\omega_r - \omega_o)t + 2v_r v_o \cos(\omega_r + \omega_o)t]
 \end{aligned}$$

- DC term can be ignored.
- $2\omega_r$ & $2\omega_o$ terms will be filtered out
- The most important terms are those of frequency $\omega_r \pm \omega_o$
- $\omega_r - \omega_o$ term will become IF signal for a receiver or down-converter.
- For a given LO frequency, there will be two RF frequencies that will mix down to the same IF frequency.
- If RF frequency is $\omega_r = \omega_o + \omega_i$, then o/p frequencies of mixer will be $\omega_r \pm \omega_o = 2\omega_o + \omega_i$ and ω_i . If RF frequency of the is $\omega_r = \omega_o - \omega_i$, the mixer o/p frequencies will be $\omega_r \pm \omega_o = 2\omega_o - \omega_i$

and $-\omega_c$. This latter ω_c is called image response of the mixer, and is indistinguishable from the direct response. One way to eliminate image response is by using an image rejection mixer.

Notes from

Bingham Young University

Posted with Permission

from Dr. Karl Klannick

Chapter 5

Mixers

A mixer is a device that multiplies two signals. In RF and microwave design, mixers are used to upconvert or downconvert a signal in frequency. If a narrowband signal centered around a carrier frequency is mixed with a sinusoidal signal at the same frequency as the carrier, one of the mixing products that appears at the output is the narrowband signal centered at DC. Often, instead of mixing a signal all the way to DC, it is common to mix to an intermediate frequency (IF) such as 70 MHz or 140 MHz that is much smaller than the carrier frequency. Further processing and detection of the information carried in the signal can then be done at the lower frequency with much simpler circuits than would be required at the original carrier frequency.

RF mixers can also be used for modulation/demodulation, although this is uncommon since most modern communication signals use complex modulations which would require two mixers with nearly identical phase performance. Since this is difficult to construct at high frequencies, modulation is usually done at a lower IF frequency and then the signal is upconverted to a center frequency in the microwave band.

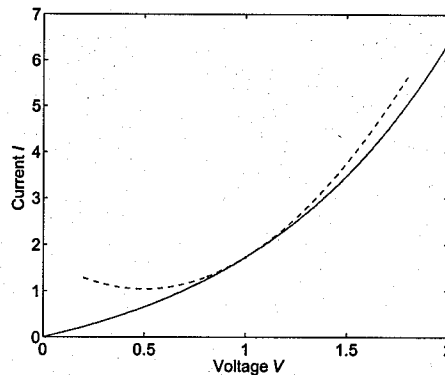

Figure 5.1: Nonlinear diode current/voltage characteristic. Solid line: Eq. (5.1) with $\alpha = I_s = 1$. Dashed line: second order approximation using the first three terms of Eq. (5.2).

One way to perform mixing is take two signals of similar strength, add them together, and then run them through a diode. To see how this works mathematically, consider that a diode has a voltage-current relationship of

$$I(V) = I_s(e^{\alpha V} - 1) \quad (5.1)$$

If the voltage is written as $V = V_o + v$, where V_o is a DC bias voltage and v is a small AC term, then we

can write a Taylor series of the current as

$$I(V_o + v) = I(V_o) + v \left. \frac{dI}{dV} \right|_{V=V_o} + \frac{v^2}{2} \left. \frac{d^2I}{dV^2} \right|_{V=V_o} + \dots \quad (5.2)$$

where we can neglect higher order terms as long as v is small. Defining $dI/dV = 1/R_j$ at $V = V_o$, where R_j is the small-signal junction resistance, then $d^2I/dV^2 = \alpha/R_j$ at $V = V_o$. If $v = v_1 + v_2$, then the second-order term in the Taylor series produces

$$\frac{v^2}{2} \left. \frac{d^2I}{dV^2} \right|_{V=V_o} = \frac{\alpha}{2R_j} (v_1^2 + 2v_1v_2 + v_2^2) \quad (5.3)$$

The middle term performs the multiplication we desire. So, all we have to do is match the diode to the feedline in order to maximize the voltage across the diode junction and thereby maximize the signal strength of the multiplied signal.

This nonlinear diode relationship also indicates how to do power detection. We often need to do power sampling in a wireless communication system, for example, when the gain of the receiver must be automatically varied depending on the received signal strength. If the input voltage is $v(t) = A \cos \omega t$, then the squaring operation leads to

$$\frac{v^2}{2} \left. \frac{d^2I}{dV^2} \right|_{V=V_o} = \frac{\alpha A^2}{4R_j} [1 + \cos(2\omega t)] \quad (5.4)$$

Filtering out the term at $2\omega t$ leaves a DC term that is proportional to the received signal power (voltage squared).

5.1 Switching (Sampling) Mixers

The diode mixer described above is relatively straightforward to design and build, and is used in some cases for special purpose designs, but most commercial mixers use an different approach based on switching. Switching mixers are not as intuitive as nonlinear mixing, but can be readily analyzed using Fourier analysis.

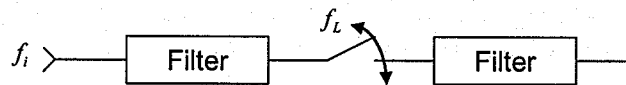

Figure 5.2: A simple sampling mixer configuration.

Consider a system with a high-speed switch that samples an input signal at frequency f_i at a sample rate of f_L . The system is shown in Fig. 5.2. Assume that the switch is an ideal sampling device for now, which means that it is closed only instantaneously. The sampling function is therefore a sequence of delta functions. The spectrum of the sampling function will also be a sequence of delta functions, as shown in Fig. 5.3.

Since we are multiplying the signal by $v_L(t)$, we are convolving in the frequency domain. This will replicate the signal spectrum at f_L intervals in the frequency domain. We can then filter out images of the spectrum that we do not want. Note that we call v_L the *Local Oscillator (LO)* signal. The high frequency signal is typically called the *Radio Frequency (RF)* signal, and the low frequency signal the *Intermediate Frequency*

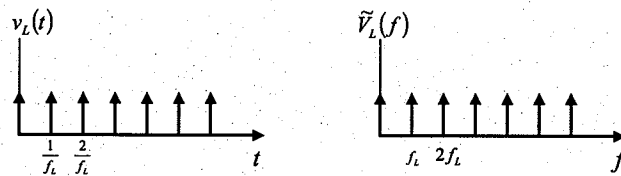

Figure 5.3: Sampling voltage and spectrum.

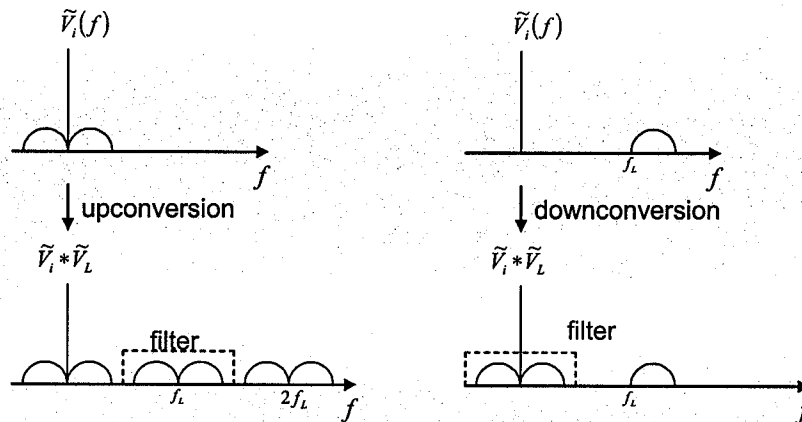

Figure 5.4: Sampling mixer up- and downconversion of a signal.

(*IF*) signal. If the RF is the input, IF is the output (downconversion). If the IF is the input, the RF is the output (upconversion). Upconversion and downconversion are represented in the spectral domain in Fig. 5.4.

Now, suppose $v_L(t)$ is not a train of impulses, but rather some periodic function with a period of $T_L = 1/f_L$. $\tilde{V}_L(f)$ will still be impulses at nf_L . However, they will not be equal amplitude, since the spectrum of the sampling function decays with frequency. This is what we obtain using a diode as the switching device (Fig. 5.5).

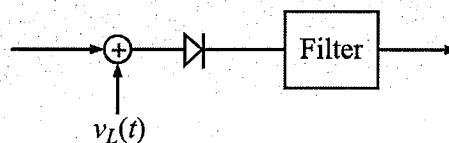

Figure 5.5: Diode switching mixer.

The local oscillator is a strong signal, which when positive causes the diode to conduct (switch closed), when negative causes the diode to be reverse biased (switch open). If the required turn-on voltage of the diode is v_d , then the diode is on when the switching signal is greater than v_d , as shown in Fig. 5.6.

For simplicity, we will assume that the switching voltage is strong enough that we can neglect the tiny turn-on voltage V_d , which means that when $v_L > 0$ the diode conducts. Mathematically, we can write

$$v_o(t) = [v_L(t) + v_i(t)] S_s(t) \tag{5.5}$$

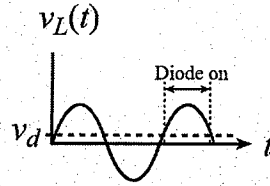

Figure 5.6: Diode voltage over one cycle of the switching signal.

where

$$\begin{aligned}
 S_s(t) &= \begin{cases} 1 & v_L > 0 \\ 0 & v_L < 0 \end{cases} \\
 &= \frac{1}{2} + \frac{2}{\pi} \sum_{n=1}^{\infty} \frac{1}{n} \sin\left(\frac{n\pi}{2}\right) \cos(n\omega_L t)
 \end{aligned} \tag{5.6}$$

Therefore, if we assume that $v_i(t) = V_i \cos \omega_i t$ and $v_L(t) = V_L \cos \omega_L t$, then

$$\begin{aligned}
 v_o(t) &= \frac{1}{2}v_L(t) + \frac{1}{2}v_i(t) + \frac{2}{\pi} \sum_{n=1}^{\infty} \frac{1}{n} \sin\left(\frac{n\pi}{2}\right) \{V_L \cos(n\omega_L t) \cos(\omega_L t) + V_i \cos(n\omega_L t) \cos(\omega_i t)\} \\
 &= \frac{1}{2}v_L(t) + \frac{1}{2}v_i(t) + \frac{1}{\pi} \sum_{n=1}^{\infty} \frac{1}{n} \sin\left(\frac{n\pi}{2}\right) \{V_L \cos[(n-1)\omega_L t] + V_L \cos[(n+1)\omega_L t] + \\
 &\quad V_i \cos[(n\omega_L - \omega_i)t] + V_i \cos[(n\omega_L + \omega_i)t]\}
 \end{aligned} \tag{5.7}$$

Note that the $\sin(n\pi/2)$ term is zero for n even. Therefore, we will have signals at

1. ω_i
2. ω_L
3. $m\omega_L$ for m even
4. $n\omega_L \pm \omega_i$ for n odd

The desired term will be either $\omega_L + \omega_i$ for upconversion or $\omega_L - \omega_i$ for downconversion. The remaining undesired components will need to be filtered out.

5.2 Single Balanced Mixers

The simple mixer introduced above is a single-ended mixer. We have shown that this mixer produces a large variety of undesired signals. If we use a more balanced configuration, then some of these undesired signals can be suppressed. For example, consider the single-balanced mixer shown below:

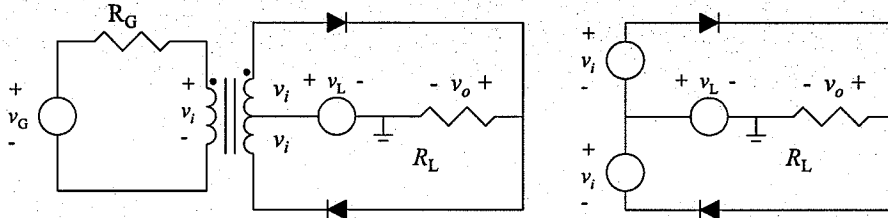

Figure 5.7: Single-balanced diode switching-type mixer.

For this circuit,

$$\begin{aligned}
 v_o &= \begin{cases} v_L + v_i & v_L > 0 \\ v_L - v_i & v_L < 0 \end{cases} \\
 &= v_L + v_i S_b(t)
 \end{aligned} \tag{5.8}$$

where

$$\begin{aligned}
 S_b(t) &= \begin{cases} +1 & v_L > 0 \\ -1 & v_L < 0 \end{cases} \\
 &= \frac{4}{\pi} \sum_{n=1}^{\infty} \frac{1}{n} \sin\left(\frac{n\pi}{2}\right) \cos(n\omega_L t)
 \end{aligned} \tag{5.9}$$

So,

$$v_o(t) = v_L(t) + \frac{2V_i}{\pi} \sum_{n=1}^{\infty} \frac{1}{n} \sin\left(\frac{n\pi}{2}\right) \{ \cos[(n\omega_L - \omega_i)t] + \cos[(n\omega_L + \omega_i)t] \} \tag{5.10}$$

We now have signals at

1. ω_L
2. $n\omega_L \pm \omega_i$ for n odd

The balanced configuration has removed many of our undesired components. This tends to be a good choice for downconversion, since $\omega_L \gg \omega_L - \omega_i$, so it is easy to filter out the undesirable signals at ω_L and $n\omega_L \pm \omega_i$ for $n > 1$.

If we augment this single-balanced design as follows: we can ALSO suppress the LO. In this case,

$$v_o(t) = v_i(t)S_s(t) = \frac{1}{2}v_i(t) + \frac{V_i}{\pi} \sum_{n=1}^{\infty} \frac{1}{n} \sin\left(\frac{n\pi}{2}\right) \{ \cos[(n\omega_L - \omega_i)t] + \cos[(n\omega_L + \omega_i)t] \} \tag{5.11}$$

This is a good choice for upconversion since $\omega_L \gg \omega_i$.

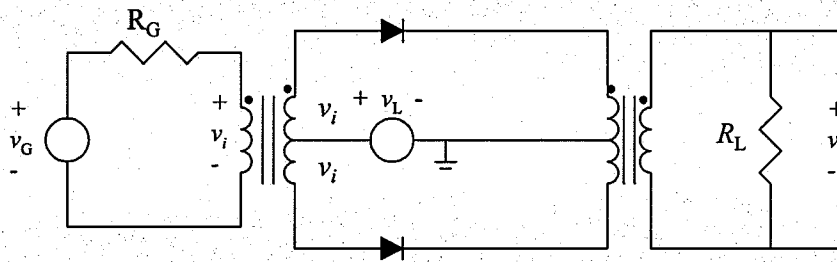

Figure 5.8: Alternate single-balanced diode switching-type mixer.

5.3 Double Balanced Mixer

To suppress both the signal and LO frequencies, we must go to a double balanced design:

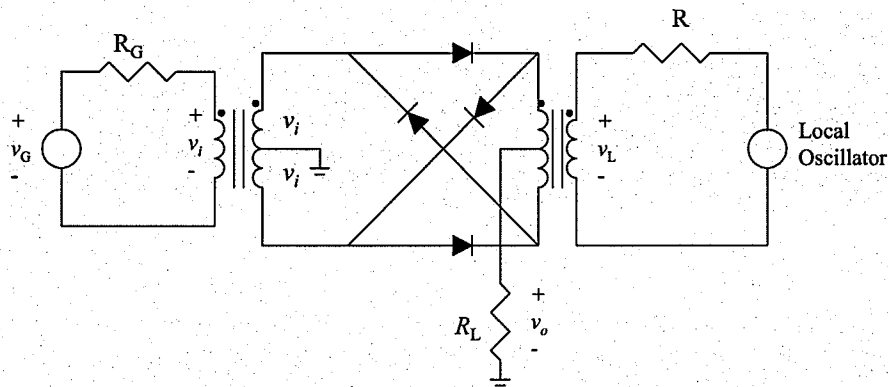

Figure 5.9: Double-balanced diode switching-type mixer.

For $v_L > 0$, we can simplify the circuit by removing the diodes that are off:

For the simplified circuit ($v_L > 0$):

$$v_i - (i_1 - i_2)R_L + v_L - r_d i_1 = 0 \tag{5.12}$$

$$v_i - (i_1 - i_2)R_L - v_L + r_d i_2 = 0 \tag{5.13}$$

Adding these equations leads to

$$2v_i - 2R_L(i_1 - i_2) - r_d(i_1 - i_2) = 0 \tag{5.14}$$

$$i_1 - i_2 = \frac{v_i}{R_L + r_d/2} = -\frac{v_o}{R_L} \tag{5.15}$$

For $v_L > 0$, we have

$$\frac{v_o}{v_i} = -\frac{R_L}{R_L + r_d/2} \tag{5.16}$$

A similar analysis for $v_L < 0$ leads to

$$\frac{v_o}{v_i} = \frac{R_L}{R_L + r_d/2} \tag{5.17}$$

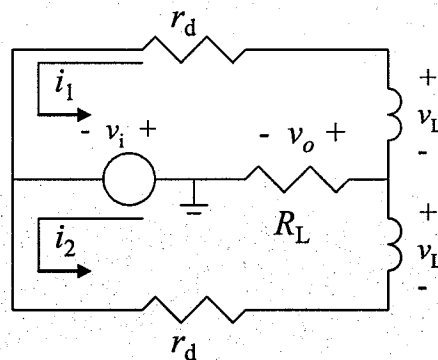
Figure 5.10: Simplified double-balanced mixer circuit for $v_L > 0$.

Combining these two results leads to

$$\begin{aligned} v_o &= \frac{R_L}{R_L + r_d/2} v_i S_b(t) \\ &= \frac{R_L}{R_L + r_d/2} \frac{2V_i}{\pi} \sum_{n=1}^{\infty} \frac{1}{n} \sin\left(\frac{n\pi}{2}\right) \{\cos[(n\omega_L - \omega_i)t] + \cos[(n\omega_L + \omega_i)t]\} \end{aligned} \quad (5.18)$$

This shows that the double balanced mixer eliminates both the LO and input signals at the output.

5.3.1 Conversion Loss

For the double-balanced mixer,

$$R_{in} = \frac{v_i}{i_1 - i_2} = R_L + r_d/2 \approx R_L \quad (5.19)$$

The maximum available power from the source is

$$P_i = \frac{V_p^2}{8R_L} \quad (5.20)$$

where V_p is the peak value of the source sinusoidal signal. The peak of the output voltage in a single sideband is then

$$V_o = \frac{2V_i}{\pi} = \frac{V_p}{\pi} \quad (5.21)$$

due to the voltage division of V_p . The output power is

$$P_o = \frac{V_p^2}{2\pi^2 R_L} \quad (5.22)$$

and the conversion loss is

$$L = \frac{P_i}{P_o} = \frac{\pi^2}{4} \quad (5.23)$$

$$L_{dB} = 10 \log\left(\frac{\pi^2}{4}\right) = 3.92 \text{ dB} \approx 4 \text{ dB} \quad (5.24)$$

For the single-balanced mixer,

$$L_{dB} = 9.94 \text{ dB} \approx 10 \text{ dB} \quad (5.25)$$